ADAPTACLAD® RS

ARCHITECTURAL DESIGN FRONT-END INFORMATION

30 psf (ASD) / 50 psf (LRFD) Structural Capacity

SYSTEM OVERVIEW

Laminators Inc. AdaptaClad RS is a weather-resistant, exterior wall covering panel system that combines a dry-seal, reveal-joint aesthetic with drained and back ventilated rainscreen performance. The panel system includes shop-fabricated Omega-Lite® FR aluminum composite material (ACM) panels, aluminum panel extrusions and clips, and accessories. The panel system can be installed over a variety of substrates and on projects requiring Continuous Insulation (CI), such as Laminators Inc. Omega CI® rigid insulation panels or other third-party CI solutions.

ARCHITECTURAL DESIGN

This Laminators Inc. Architectural Design detail set consists of front-end information & details and is complete with respect to Architectural Design. The front-end information outlines all applicable information for the panels and panel system. The details represent the panel system in relationship to a typical exterior wall assembly and may be applied to project-specific exterior wall assembly drawings & specifications with consideration of potential impact on air, structural, water, and/or fire testing performance. The details may not be applied to project-specific shop drawings. Although not required for Architectural Design, additional information is available in the Shop Fabrication and Field Installation detail sets.

To consult directly with one of our Professional Engineers (PE) regarding the panel system, contact Laminators Inc. Technical Support during business hours (8 a.m. – 5 p.m. EST):

800.523.2347
LaminatorsInc.com
engineering@laminatorsinc.com

FEATURES

The panel system has been designed and detailed to include the following:

1. Fabricated panels with long sides up to 142” and short sides up to 46” (for all finish colors) or 58” (for select finish colors), including options for color-matched rivets
2. Installation over a variety of substrates; however, installation over open framing lacking any substrate sheathing is not permitted
3. Defined perimeter extrusion, panel stiffener, and panel clip locations & spacings

Go beyond the panel... and go to the next level!

4. Elevations with representative joints, edges, openings, transitions, and penetrations
5. Sections with system depth, representative substrate, fabricated panels, insert strips, perimeter extrusions, panel clips, typical joints with dimensions, and representative flashings

CODES & STANDARDS

Laminators Inc. retains Professional Engineers (PE) licensed in the state of primary research & development, design, and manufacturing (i.e., Commonwealth of Pennsylvania) to provide structural design, detailing, and testing support for the panel system. Accordingly, the panel system has been designed and detailed to the 2018 International Building Code (IBC), including the following, applicable Referenced Standards:

1. ACI 318: Building Code Requirements for Structural Concrete
2. ADM: Aluminum Design Manual: Part 1 – A Specification for Aluminum Structures
3. AISI S100: North American Specification for the Design of Cold-formed Steel Structural Members, 2016
4. ANSI/AWC NDS: National Design Specification (NDS) for Wood Construction – with 2018 NDS Supplement
5. ASCE/SEI 7: Minimum Design Loads and Associated Criteria for Buildings and Other Structures
6. TMS 402/602: Building Code Requirements and Specification for Masonry Structures

The panel system has been tested to, and/or complies with, the following, applicable Referenced Standards:

1. AAMA 501.1 Standard Test Method for Water Penetration of Windows, Curtain Walls and Doors Using Dynamic Pressure
2. AAMA 509 Voluntary Test and Classification Method for Drained and Back Ventilated Rainscreen Wall Cladding Systems
3. AAMA 2605 Voluntary Specification, Performance Requirements and Test Procedures for Superior Performing Organic Coatings on Aluminum Extrusions and Panels (with Coil Coating Appendix)
4. ASTM A653 Standard Specification for Steel Sheet, Zinc-Coated (Galvanized) or Zinc-Iron Alloy-Coated (Galvannealed) by the Hot-Dip Process
5. ASTM B209 Specification for Aluminum and Aluminum Alloy Steel and Plate
6. ASTM B221 Standard Specification for Aluminum and Aluminum-Alloy Extruded Bars, Rods, Wire, Profiles, and Tubes
7. ASTM C645 Standard Specification for Nonstructural Steel Framing Members

8. ASTM D635 Standard Test Method for Rate of Burning and/or Extent and Time of Burning of Plastics in a Horizontal Position
9. ASTM D1929 Standard Test Method for Determining Ignition Temperature of Plastics
10. ASTM D2244 Standard Practice for Calculation of Color Tolerances and Color Differences from Instrumentally Measured Color Coordinates
11. ASTM D4214 Standard Test Methods for Evaluating the Degree of Chalking of Exterior Paint Films
12. ASTM E84 Standard Test Method for Surface Burning Characteristics of Building Materials
13. ASTM E283 Standard Test Method for Determining Rate of Air Leakage Through Exterior Windows, Curtain Walls, and Doors Under Specified Pressure Differences Across the Specimen
14. ASTM E330 Standard Test Method for Structural Performance of Exterior Windows, Doors, Skylights and Curtain Walls by Uniform Static Air Pressure Difference
15. ASTM E331 Standard Test Method for Water Penetration of Exterior Windows, Skylights, Doors, and Curtain Walls by Uniform Static Air Pressure Difference
16. ASTM E529 Standard Guide for Conducting Flexural Tests on Beams and Girders for Building Construction
17. NFPA 285 Standard Fire Test Method for Evaluation of Fire Propagation Characteristics of Exterior Wall Assemblies Containing Combustible Components

CAPACITY

It is the responsibility of the Design Professional of Record (DPR) to establish the *Required Strength* of the panel system based on project-specific Components and Cladding (C&C) wind loads. By reference to the IBC, C&C wind loads are calculated per ASCE/SEI 7.

It is the responsibility of Laminators Inc. to establish the *Available Strength* of the panel system based on codes, standards, and industry-accepted specifications. From design and testing, the structural capacity of the panel system for this detail set has been established at **30 psf (ASD) / 50 psf (LRFD)**.

Accordingly, the project-specific C&C wind loads (*Required Strength*) shall not exceed the structural capacity of the panel system (*Available Strength*). For C&C wind loads greater than the structural capacity, contact Laminators Inc. Technical Support.

CRITERIA

For Laminators Inc. to provide the *Available Strength* of the panel system, it is the responsibility of the DPR to verify that the project-specific drawings & specifications meet the following baseline criteria for the applicable substrate:

1. Gypsum sheathing over CFSF studs or CI solutions with CFSF rails:
 - a. Spacing: 16" or 24"
 - b. Face flange width: 1-1/4" (min)
 - c. Thickness: 18 ga. (43 mils)
 - d. Tensile strength (Fu): 45 ksi
2. Plywood sheathing:
 - a. Thickness: 5/8"
 - b. Specific gravity (G): 0.55 (Southern Pine)
3. OSB sheathing:
 - a. Thickness: 5/8"
 - b. Specific gravity (G): 0.49 (Southern Pine)
4. Concrete:
 - a. Normal weight
 - b. Compressive strength (f'c): 2500 psi
5. CMU:
 - a. Normal weight
 - b. Compressive strength (f'm): 2000 psi
 - c. Type II units
 - d. Face shell thickness: 1-1/4" (min)
 - e. Grade N mortar

Note: If the project-specific drawings & specifications do not meet the baseline criteria for the applicable substrate, contact Laminators Inc. Technical Support.

NFPA 285 COMPLIANCE

As represented in the Laminators Inc. Architectural Design details, the panel system in relationship to a typical exterior wall assembly has been tested in accordance with, and meets the Conditions of Acceptance of, NFPA 285. The panel system may be considered a baseline and appropriately applied to project-specific exterior wall assembly drawings & specifications.

An Engineering Evaluation (EEV) is available from Laminators Inc. Technical Support that presents specific engineering extensions and permits substitutions with respect to base wall components, fire-stopping at floor lines, cavity insulation, exterior sheathing, water-resistive barriers, and exterior insulation, while maintaining NFPA 285 compliance. The EEV may be required for project-specific submissions to an Authority Having Jurisdiction (AHJ).

If any engineering extensions are required beyond what is presented in the EEV, it is the responsibility of a third-party to pursue a separate EEV that permits other intended substitutions. Note that Laminators Inc. cannot serve as the third-party in pursuing this EEV.

While an EEV addresses fire performance, the application of any project-specific substitutions will need to be evaluated by the DPR with respect to potential impact on air, structural, and/or water performance of the exterior wall assembly.

COLOR COORDINATION & PLANNING

Coordinate with Laminators Inc. on large projects to ensure the most consistent color matches between project phases.

METALLIC & ANODIZED FINISHES

Variation and directionality are common characteristics across a range of colors, finishes, patterns, and textures of panel finishes. Therefore, project-specific coordination of panel orientation is particularly important for metallic paint and anodized aluminum finishes. Directional arrows are printed on the masking to assist with same-direction panel orientation during Shop Fabrication and Field Installation.

WARRANTY

To satisfy the ACM Manufacturer's Material Warranty requirement of project-specific specifications, a Limited Warranty document is available from the Laminators Inc. Sales/Customer Service team that is project-specific and consists of two parts: a *Panel Material and Product Warranty* and a *Panel and Extrusion Finish Warranty*. The Limited Warranty is subject to stated terms, conditions, limitations, remedies, legal rights, and a disclaimer. Failure of the project-specific exterior wall assembly drawings & specifications to be in general conformance with the Laminators Inc. Architectural Design detail set may void one or both parts of the Limited Warranty. Laminators Inc. does not support any Field Installation warranty.

ADDITIONAL INFORMATION

In addition to the Laminators Inc. Architectural Design, Shop Fabrication, and Field Installation detail sets, information is available in Laminators Inc. Specification Section 07 42 13.23 – Aluminum Composite Material Wall Panels and on the Laminators Inc. [YouTube](#) channel.

ADAPTACLAD[®] RS

ARCHITECTURAL DESIGN DETAILS

30 psf (ASD) / 50 psf (LRFD) Structural Capacity

DRAWING INDEX

REV 01, 5/7/2024

DWG NO.	TITLE	REV DATE	REV	CHANGE FROM PREVIOUS REV
A-101.30	COORDINATION ELEVATIONS – VERTICAL FRAMING	4/8/2024	00	
A-102.30	COORDINATION ELEVATIONS – HORIZONTAL FRAMING	4/8/2024	00	
A-103.30	COORDINATION ELEVATIONS – CONTINUOUS SUBSTRATES	4/8/2024	00	
A-104	COORDINATION DETAILS – PANEL ALIGNMENT	4/8/2024	00	
A-105	COORDINATION DETAILS – XL PANEL CLIPS	4/8/2024	00	
A-106.30	FABRICATION OVERVIEW – COMPONENT LAYOUT	4/8/2024	00	
A-107	SPECIFIC CONDITIONS – PANEL STIFFENER SPAN	4/8/2024	00	
A-201	TYPICAL ELEVATION – JOINTS, EDGES, & OPENINGS	4/8/2024	00	
A-202	TYPICAL ELEVATION – TRANSITIONS & PENETRATIONS	4/8/2024	00	
A-203.30	TRANSITION PANEL SIZE REQUIREMENTS	4/8/2024	00	
A-301	HORIZONTAL JOINT DETAIL	4/8/2024	00	
A-302	VERTICAL JOINT DETAIL	4/8/2024	00	
A-303	BOTTOM HORIZONTAL EDGE DETAIL	4/8/2024	00	
A-304	TOP HORIZONTAL EDGE DETAIL	4/8/2024	00	
A-305	LEFT VERTICAL EDGE DETAIL	4/8/2024	00	
A-306	RIGHT VERTICAL EDGE DETAIL	4/8/2024	00	
A-307	WINDOW (OR DOOR) HEAD DETAIL	4/8/2024	00	
A-308	WINDOW SILL DETAIL	4/8/2024	00	
A-309	LEFT VERTICAL EDGE DETAIL AT WINDOW (OR DOOR) JAMB	4/8/2024	00	
A-310	RIGHT VERTICAL EDGE DETAIL AT WINDOW (OR DOOR) JAMB	4/8/2024	00	
A-311	INSIDE CORNER DETAIL	4/8/2024	00	
A-312	OUTSIDE CORNER DETAIL	4/8/2024	00	
A-313	SOFFIT-TO-WALL TRANSITION DETAIL	4/8/2024	00	
A-314	FASCIA-TO-SOFFIT TRANSITION DETAIL	4/8/2024	00	
A-315	PIPE PENETRATION DETAIL	4/8/2024	00	

DWG NO.	TITLE	REV DATE	REV	CHANGE FROM PREVIOUS REV
A-316 - A-350	<i>NOT USED</i>			
A-351	WINDOW HEAD (OR DOOR) DETAIL OVER OMEGA CI	5/7/2024	00	Detail added
A-352	VERTICAL EDGE DETAIL AT WINDOW (OR DOOR) JAMB OVER OMEGA CI	5/7/2024	00	Detail added
A-401	HORIZONTAL JOINT DETAIL (CUSTOM WIDTH)	4/8/2024	00	
A-402	VERTICAL JOINT DETAIL (CUSTOM WIDTH)	4/8/2024	00	
M-101	SHAPE PROFILES	4/8/2024	00	
M-102	INSERT STRIP SIZES	4/8/2024	00	

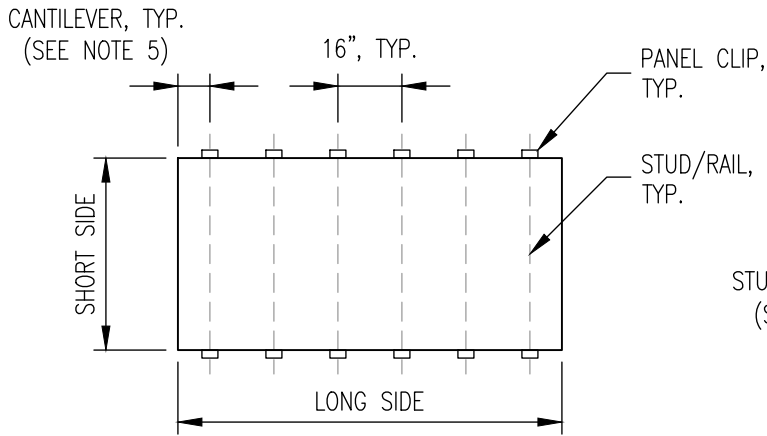

1 TYPICAL LANDSCAPE PANEL
16" VERTICAL FRAMING

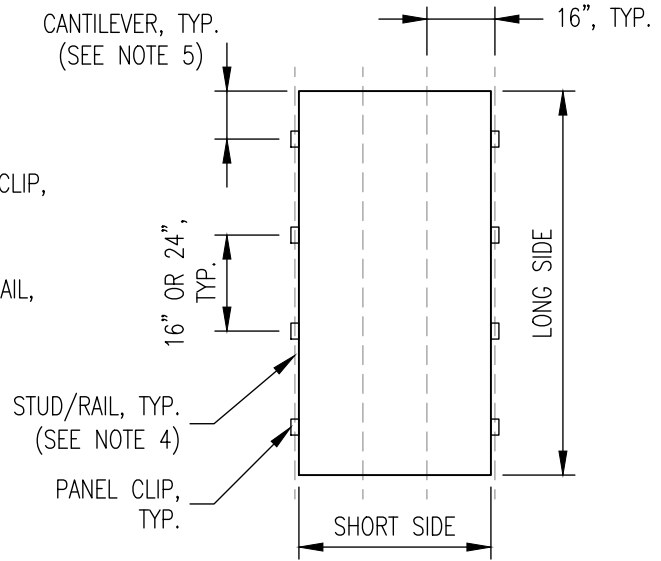

2 TYPICAL PORTRAIT PANEL
16" VERTICAL FRAMING

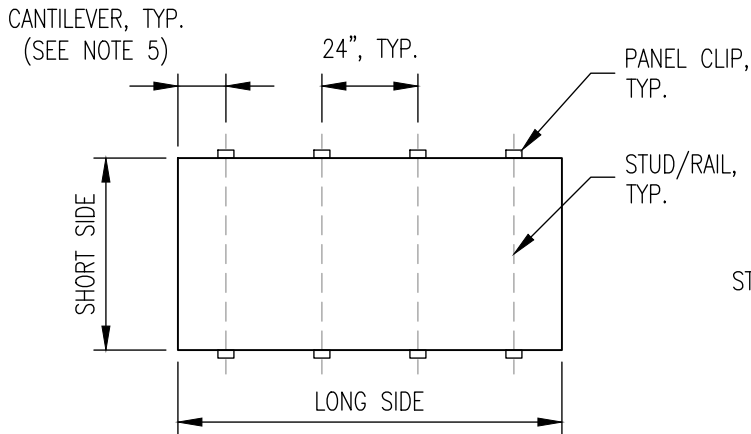

3 TYPICAL LANDSCAPE PANEL
24" VERTICAL FRAMING

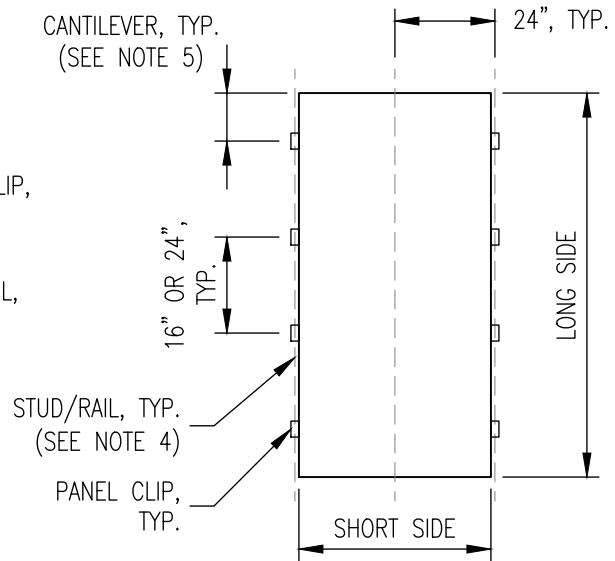

4 TYPICAL PORTRAIT PANEL
24" VERTICAL FRAMING

NOTES:

1. VERTICAL FRAMING IS DEFINED AS STUDS/RAILS; REFER TO FRONT-END INFORMATION FOR CRITERIA
2. INSTALLATION REQUIRES SUBSTRATE SHEATHING (I.E., OPEN FRAMING NOT PERMITTED)
3. PANEL CLIPS REQUIRED ON LONG SIDES OF PANEL AS SHOWN
4. FOR PORTRAIT PANELS, ALIGN VERTICAL PANEL JOINT \bar{C} AND PANEL CLIPS WITH STUD/RAIL FACE FLANGE \bar{C} (REFER TO A-104); IN THIS CONFIGURATION, PANEL CLIPS MAY BE SPACED AT 16" OR 24"
5. 16" (MAX) PANEL CANTILEVER PERMITTED OVER 16" VERTICAL FRAMING; 22" (MAX) PANEL CANTILEVER PERMITTED OVER 24" VERTICAL FRAMING
6. PANEL CLIP REFERS TO JOINT, STARTER, OR END CLIP AS REQUIRED FOR INSTALLATION
7. XL PANEL CLIPS MAY BE REQUIRED FOR ELEVATION 3 (REFER TO A-105)



COORDINATION ELEVATIONS - VERTICAL FRAMING

ADAPTA CLAD RS - 30 PSF (ASD) / 50 PSF (LRFD)

ARCHITECTURAL DESIGN DETAILS

Date: 4/8/2024	Drawn By: JJM	Detail Set: AC-RS	Dwg. No.: A-101.30	Rev: 00
-------------------	------------------	----------------------	-----------------------	------------

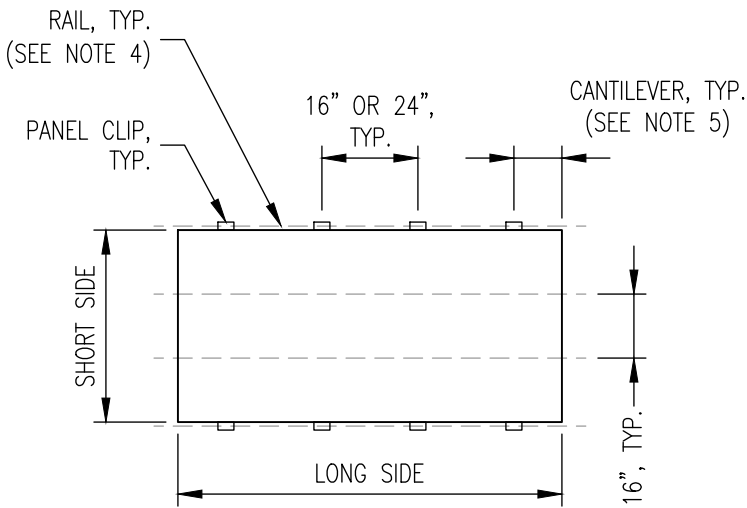

5 TYPICAL LANDSCAPE PANEL
16" HORIZONTAL FRAMING

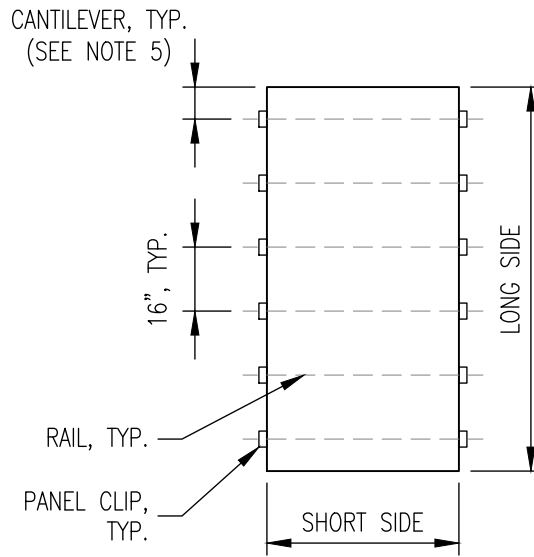

6 TYPICAL PORTRAIT PANEL
16" HORIZONTAL FRAMING

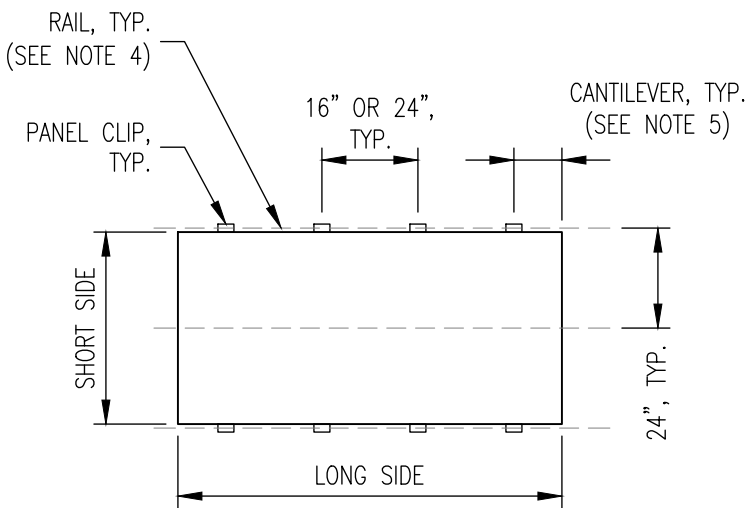

7 TYPICAL LANDSCAPE PANEL
24" HORIZONTAL FRAMING

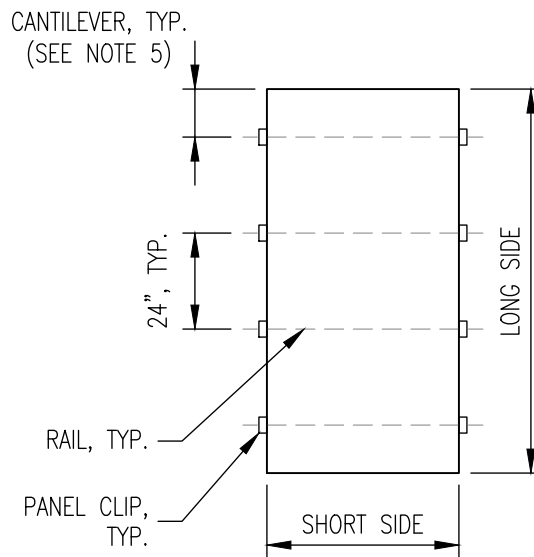

8 TYPICAL PORTRAIT PANEL
24" HORIZONTAL FRAMING

NOTES:

1. HORIZONTAL FRAMING IS DEFINED AS RAILS; REFER TO FRONT-END INFORMATION FOR CRITERIA
2. INSTALLATION REQUIRES SUBSTRATE SHEATHING (I.E., OPEN FRAMING NOT PERMITTED)
3. PANEL CLIPS REQUIRED ON LONG SIDES OF PANEL AS SHOWN
4. FOR LANDSCAPE PANELS, ALIGN HORIZONTAL PANEL JOINT C AND PANEL CLIPS WITH RAIL FACE FLANGE C (REFER TO A-104); IN THIS CONFIGURATION, PANEL CLIPS MAY BE SPACED AT 16" OR 24"
5. 16" (MAX) PANEL CANTILEVER PERMITTED OVER 16" HORIZONTAL FRAMING; 22" (MAX) PANEL CANTILEVER PERMITTED OVER 24" HORIZONTAL FRAMING
6. PANEL CLIP REFERS TO JOINT, STARTER, OR END CLIP AS REQUIRED FOR INSTALLATION
7. XL PANEL CLIPS MAY BE REQUIRED FOR ELEVATION 8 (REFER TO A-105)



LAMINATORS
Composite Panel Solutions

www.LaminatorsInc.com

800.523.2347

COORDINATION ELEVATIONS - HORIZONTAL FRAMING

ADAPTACLAD RS - 30 PSF (ASD) / 50 PSF (LRFD)
ARCHITECTURAL DESIGN DETAILS

Date:
4/8/2024

Drawn By:
JJM

Detail Set:
AC-RS

Dwg. No.:
A-102.30

Rev:
00

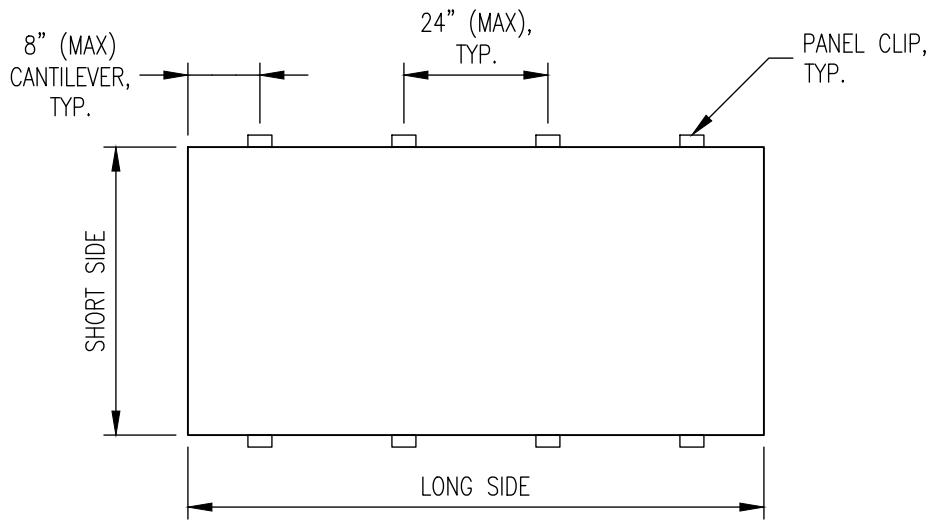

9 TYPICAL LANDSCAPE PANEL
CONTINUOUS SUBSTRATES

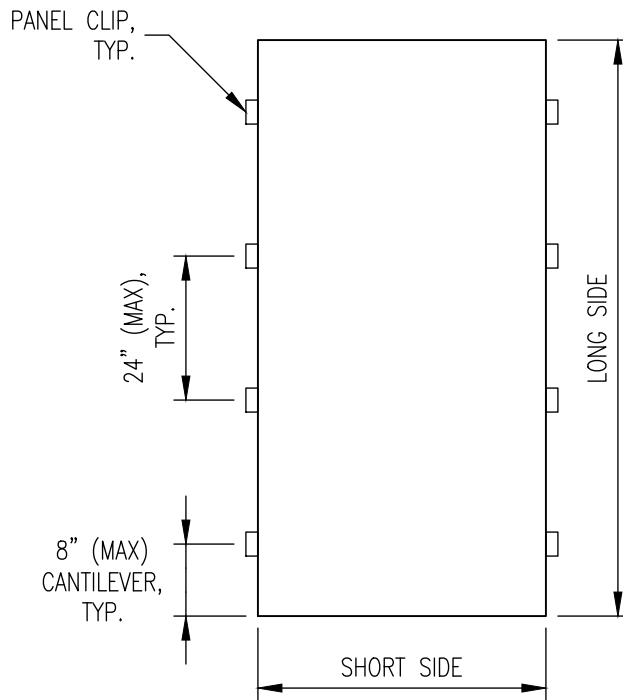

10 TYPICAL PORTRAIT PANEL
CONTINUOUS SUBSTRATES

NOTES:

1. CONTINUOUS SUBSTRATES ARE DEFINED AS OMEGA CI, PLYWOOD, OSB, CMU, AND CONCRETE; REFER TO FRONT-END INFORMATION FOR CRITERIA
2. PANEL CLIPS REQUIRED ON LONG SIDES OF PANEL AS SHOWN
3. PANEL CLIP REFERS TO JOINT, STARTER, OR END CLIP AS REQUIRED FOR INSTALLATION



LAMINATORS
Composite Panel Solutions

www.LaminatorsInc.com

800.523.2347

COORDINATION ELEVATIONS - CONTINUOUS SUBSTRATES

ADAPTACLAD RS - 30 PSF (ASD) / 50 PSF (LRFD)

ARCHITECTURAL DESIGN DETAILS

Date:
4/8/2024

Drawn By:
JJM

Detail Set:
AC-RS

Dwg. No.:
A-103.30

Rev:
00

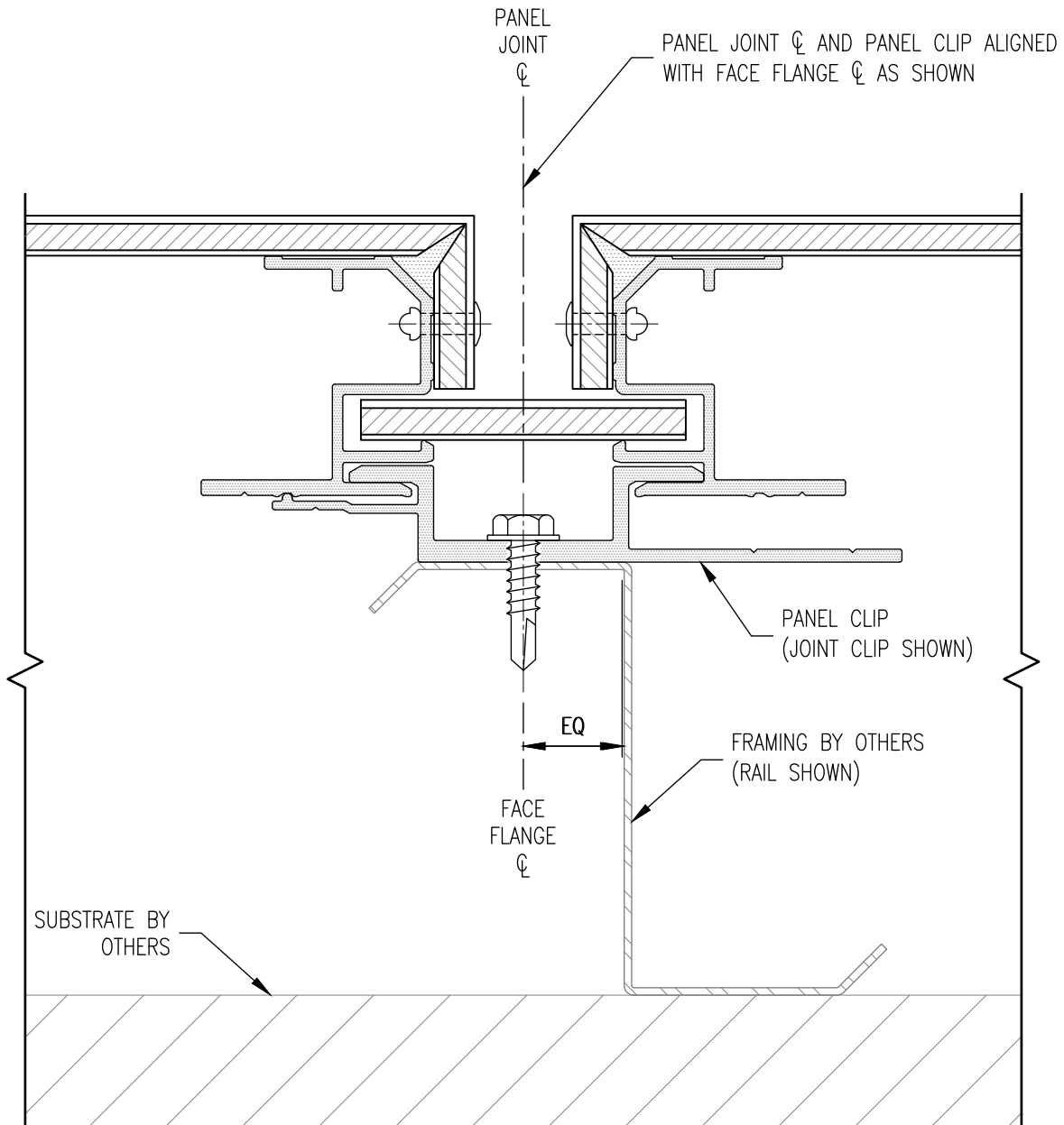

1 SECTION
JOINT ALIGNMENT

NOTES:

1. DETAIL APPLIES TO ELEVATIONS 2 & 4/A-101 AND 5 & 7/A-102
2. REFER TO A-301 FOR ADDITIONAL PANEL SYSTEM COMPONENTS NOT ANNOTATED
3. PANEL CLIP REFERS TO JOINT, STARTER, OR END CLIP AS REQUIRED FOR INSTALLATION



LAMINATORS
Composite Panel Solutions

www.LaminatorsInc.com

800.523.2347

COORDINATION DETAILS - JOINT ALIGNMENT

ADAPTACLAD RS

ARCHITECTURAL DESIGN DETAILS

Date:
4/8/2024

Drawn By:
JJM

Detail Set:
AC-RS

Dwg. No.:
A-104

Rev:
00

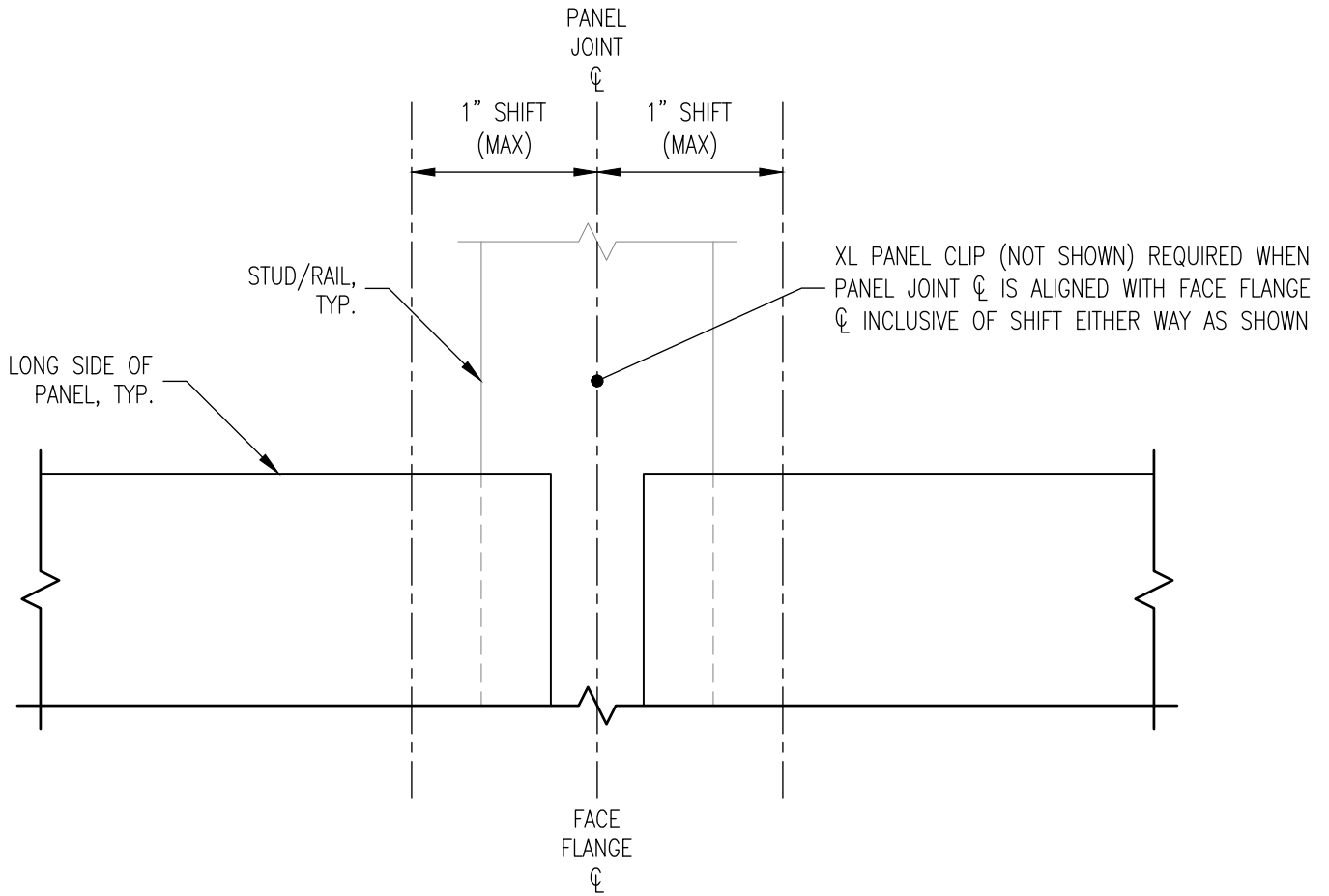

1 PARTIAL ELEVATION
XL PANEL CLIPS

NOTES:

1. DETAIL APPLIES TO ELEVATIONS 3/A-101 AND 8/A-102
2. XL PANEL CLIP NOT REQUIRED FOR PANEL JOINT ϕ SHIFT GREATER THAN 1" EITHER WAY
3. XL PANEL CLIP REFERS TO XL JOINT, XL STARTER, OR XL END CLIP AS REQUIRED FOR INSTALLATION



www.LaminatorsInc.com

800.523.2347

COORDINATION DETAILS - XL PANEL CLIPS

ADAPTACLAD RS

ARCHITECTURAL DESIGN DETAILS

Date:
4/8/2024

Drawn By:
JJM

Detail Set:
AC-RS

Dwg. No.:
A-105

Rev:
00

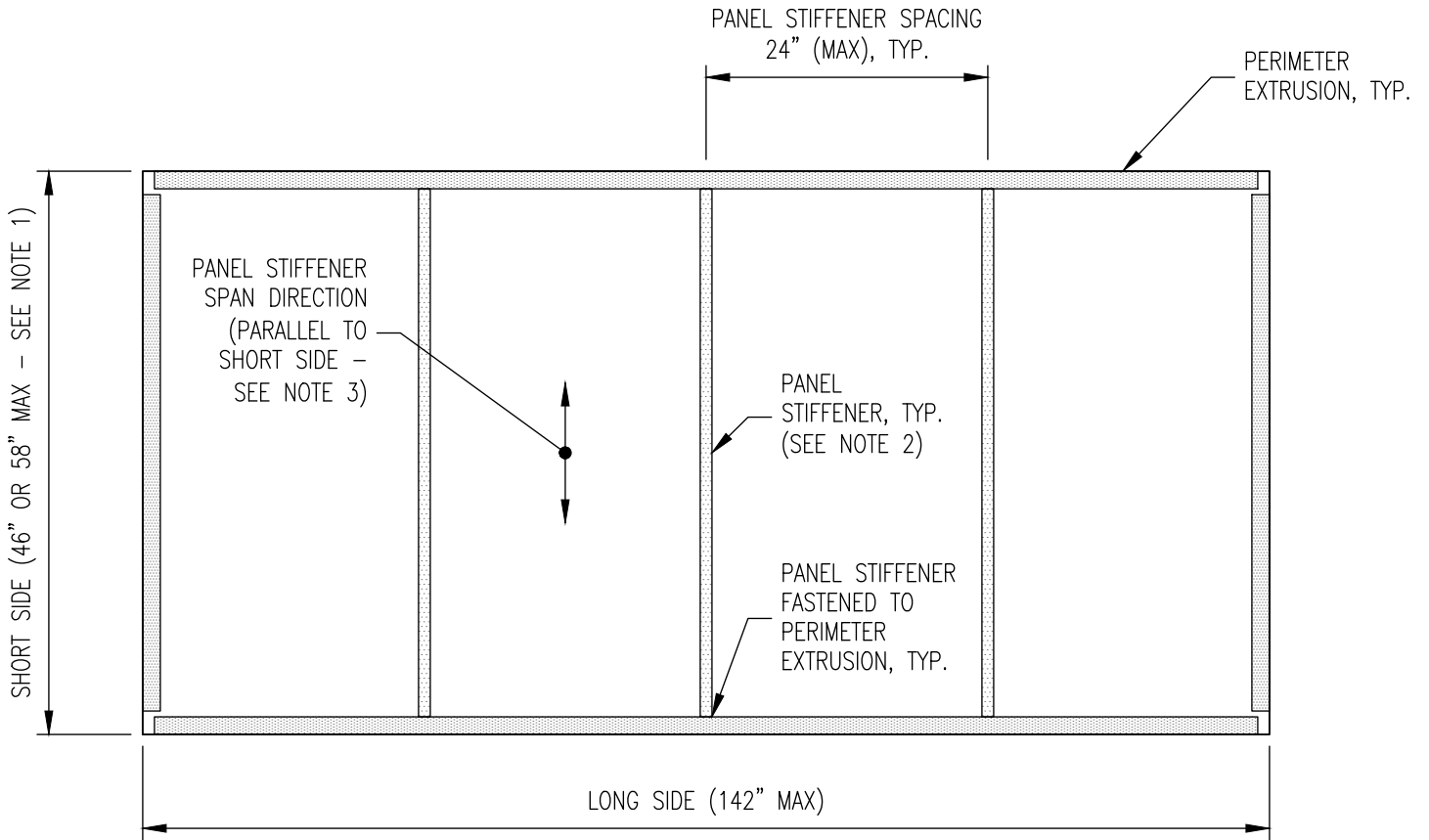

1 TYPICAL FABRICATED PANEL
COMPONENT LAYOUT

NOTES:

1. LANDSCAPE PANEL SHOWN; SHORT SIDE LIMITED TO 46" (FOR ALL FINISH COLORS) OR 58" (FOR SELECT FINISH COLORS); PORTRAIT PANEL SIMILAR
2. PANEL STIFFENER LOCATIONS ARE INDEPENDENT OF PANEL CLIP LOCATIONS (NOT SHOWN)
3. PANEL STIFFENER SPAN DIRECTION MAY BE ROTATED UNDER SPECIFIC CONDITIONS (REFER TO A-107)



LAMINATORS
Composite Panel Solutions

www.LaminatorsInc.com

800.523.2347

PANEL FABRICATION OVERVIEW - COMPONENT LAYOUT

ADAPTACLAD RS - 30 PSF (ASD) / 50 PSF (LRFD)

ARCHITECTURAL DESIGN DETAILS

Date:
4/8/2024

Drawn By:
JJM

Detail Set:
AC-RS

Dwg. No.:
A-106.30

Rev:
00

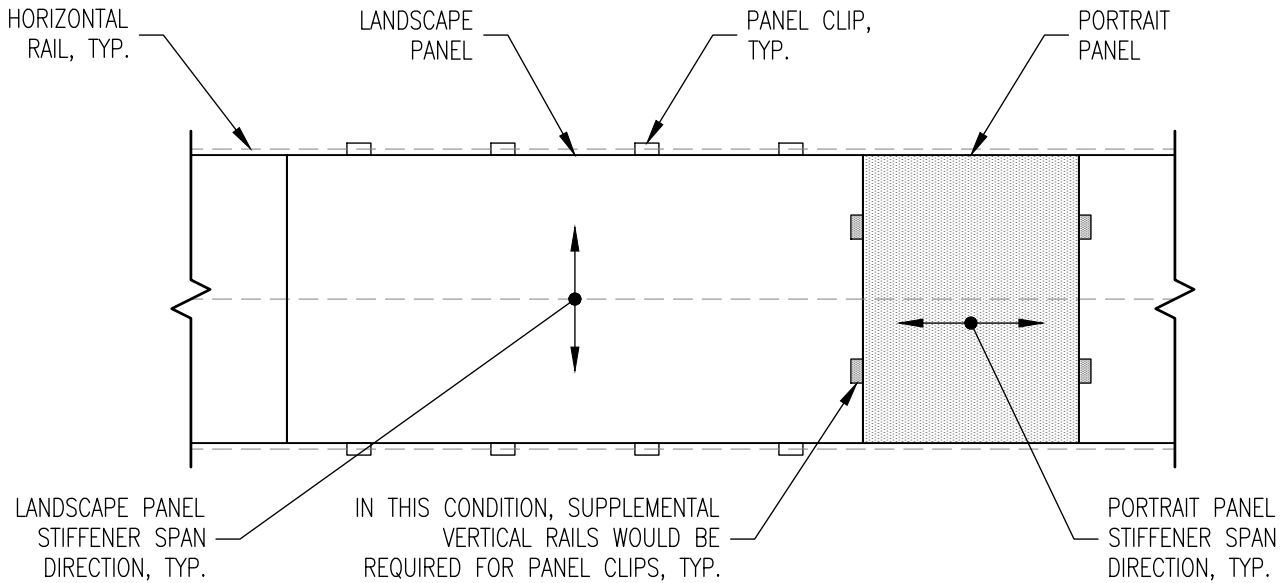

1 PARTIAL ELEVATION
TYP. SPAN DIRECTIONS

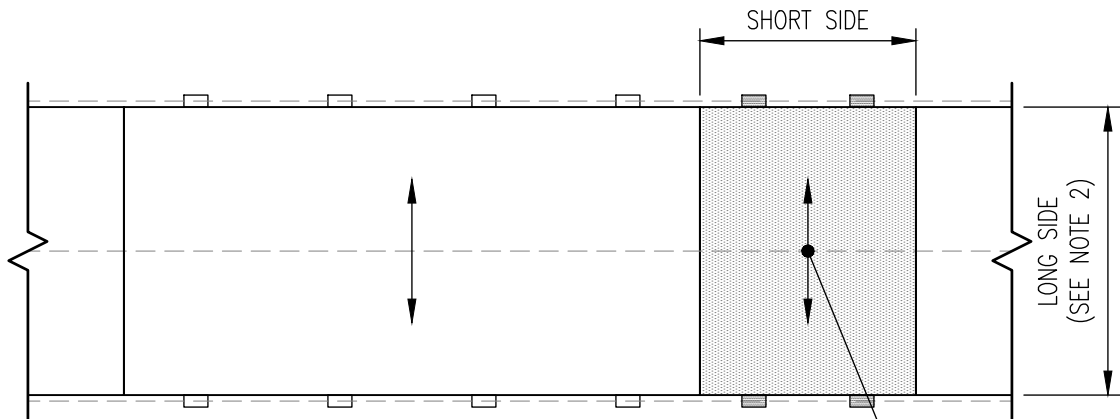

2 PARTIAL ELEVATION
ROTATED SPAN DIRECTION

NOTES:

1. ELEVATIONS ARE REPRESENTATIVE; PROJECT-SPECIFIC CONDITIONS WILL VARY
2. ROTATED PANEL STIFFENER SPAN DIRECTION PERMITTED FOR PANELS WITH LONG SIDES UP TO 46" OR 58" (BASED ON FINISH COLORS; REFER TO A-106)
3. ROTATED PANEL STIFFENER SPAN DIRECTION MUST BE REPRESENTED ON ARCHITECTURAL DRAWINGS AND COORDINATED WITH SHOP DRAWINGS BASED ON PROJECT-SPECIFIC CONDITIONS



LAMINATORS
Composite Panel Solutions

www.LaminatorsInc.com

800.523.2347

SPECIFIC CONDITIONS - PANEL STIFFENER SPAN

ADAPTACLAD RS
ARCHITECTURAL DESIGN DETAILS

Date:
4/8/2024

Drawn By:
JJM

Detail Set:
AC-RS

Dwg. No.:
A-107

Rev:
00

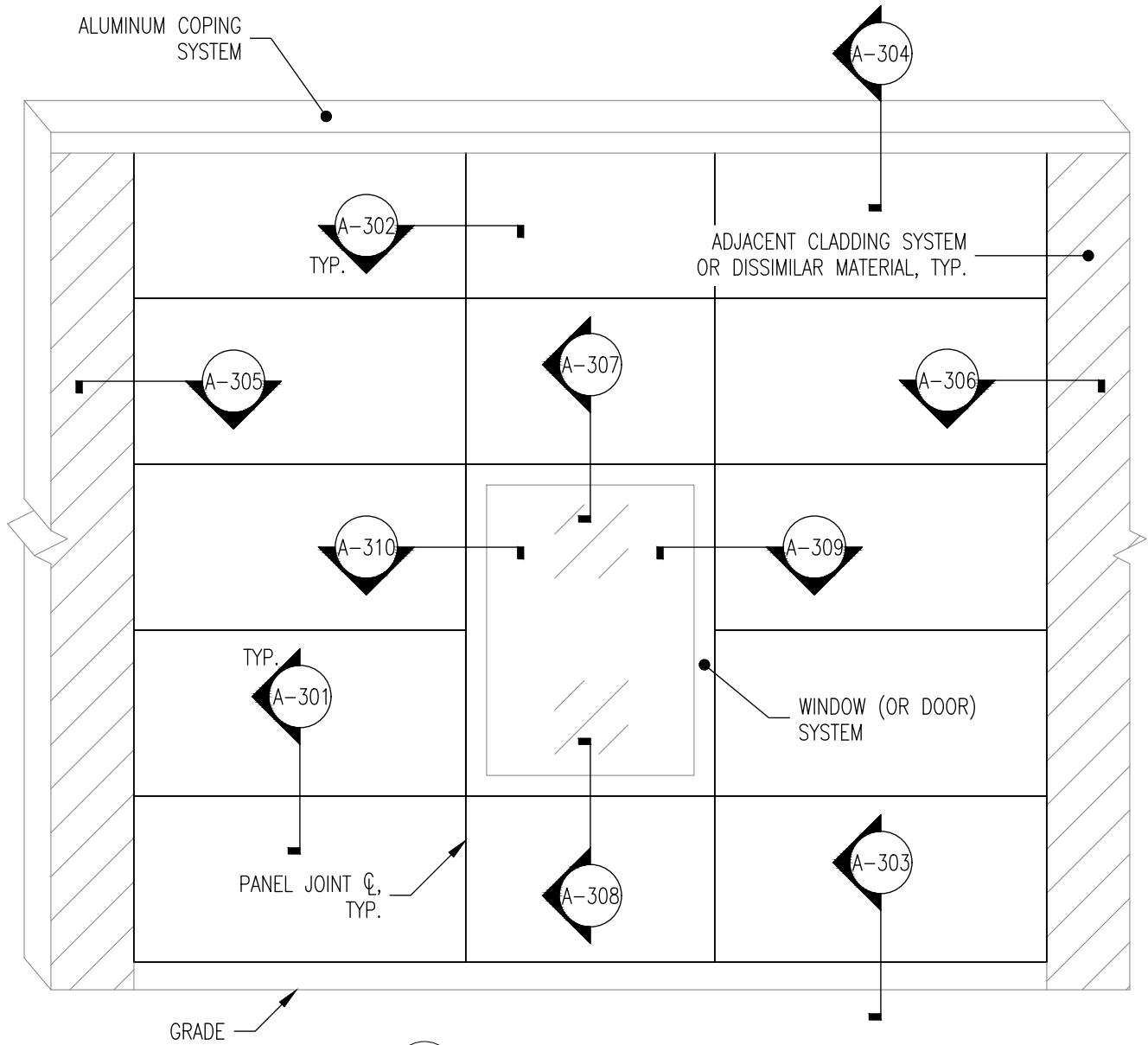

1 TYPICAL ELEVATION
JOINTS, EDGES, & OPENINGS

NOTES:

1. ELEVATION IS REPRESENTATIVE; PROJECT-SPECIFIC CONDITIONS WILL VARY
2. PROJECT-SPECIFIC SUBSTRATE CONDITIONS MAY REQUIRE SUPPLEMENTAL FRAMING



LAMINATORS
Composite Panel Solutions

www.LaminatorsInc.com

800.523.2347

TYPICAL ELEVATION - JOINTS, EDGES, & OPENINGS

ADAPTACLAD RS

ARCHITECTURAL DESIGN DETAILS

Date:
4/8/2024

Drawn By:
JJM

Detail Set:
AC-RS

Dwg. No.:
A-201

Rev:
00

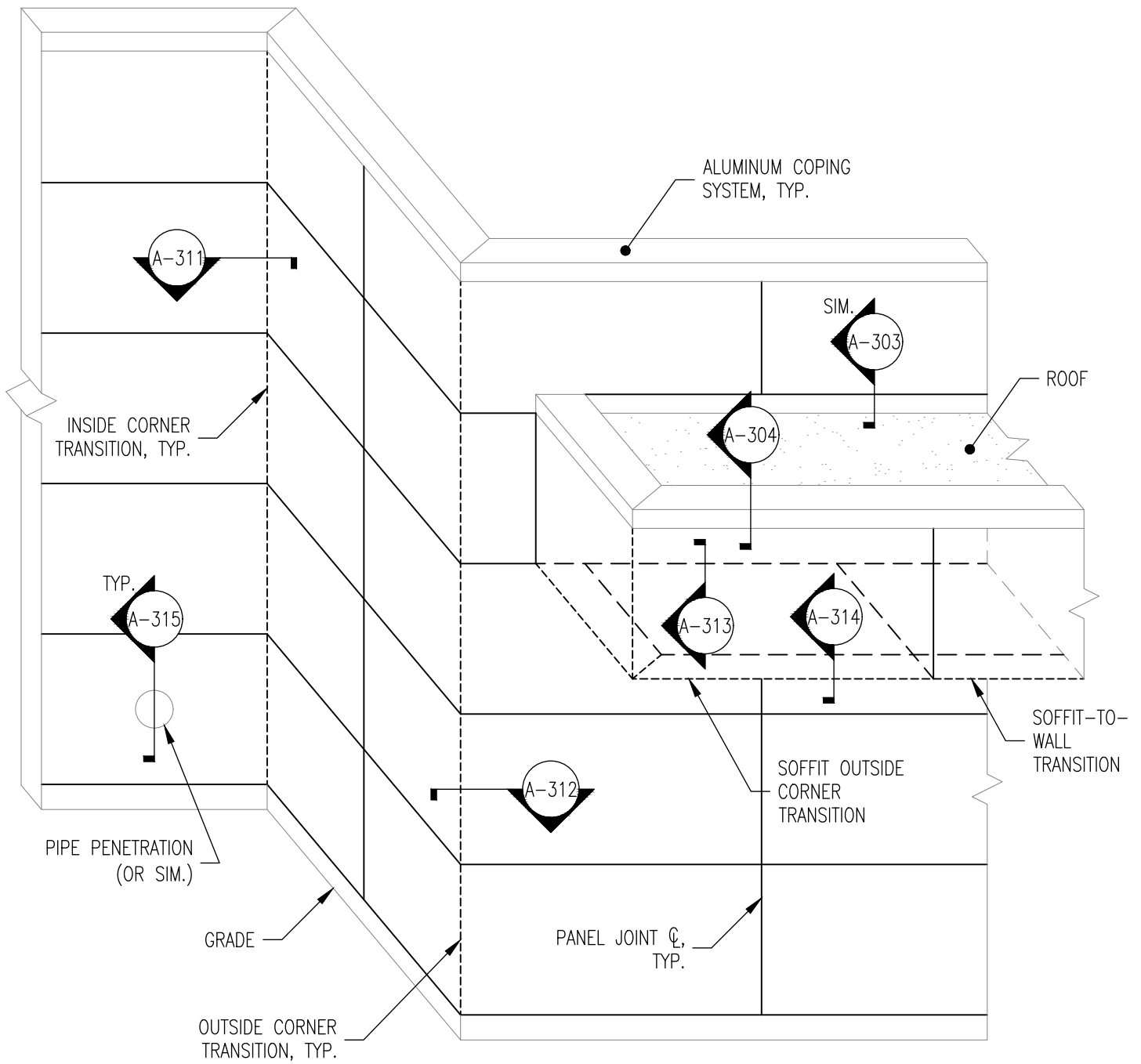

2 TYPICAL ELEVATION
TRANSITIONS & PENETRATIONS

NOTES:

1. ELEVATION IS REPRESENTATIVE; PROJECT-SPECIFIC CONDITIONS WILL VARY
2. PROJECT-SPECIFIC SUBSTRATE CONDITIONS MAY REQUIRE SUPPLEMENTAL FRAMING
3. REFER TO A-203 FOR TRANSITION PANEL SIZE REQUIREMENTS



LAMINATORS
Composite Panel Solutions

www.LaminatorsInc.com

800.523.2347

TYPICAL ELEVATION - TRANSITIONS & PENETRATIONS

ADAPTACLAD RS

TRANSITIONS & PENETRATIONS

Date:
4/8/2024

Drawn By:
JJM

Detail Set:
AC-RS

Dwg. No.:
A-202

Rev:
00

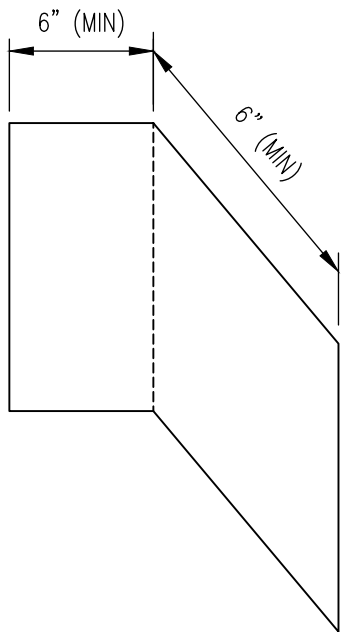

3 INSIDE CORNER
TRANSITION PANEL

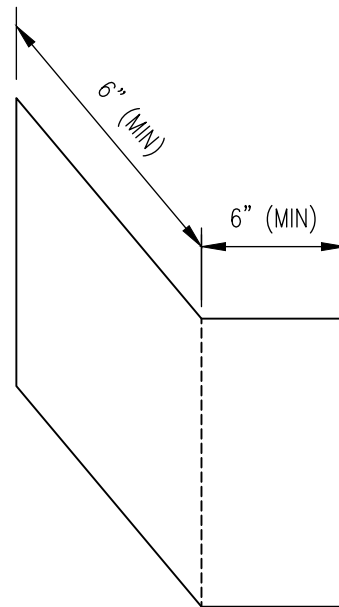

4 OUTSIDE CORNER
TRANSITION PANEL

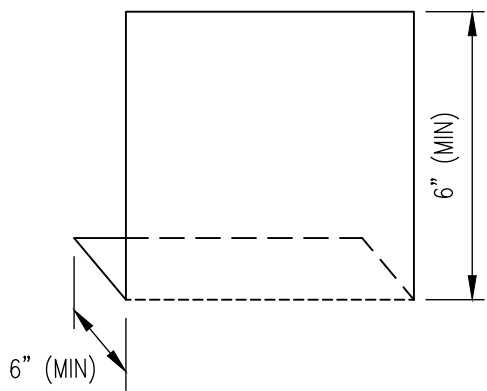

5 FASCIA-TO-SOFFIT
TRANSITION PANEL

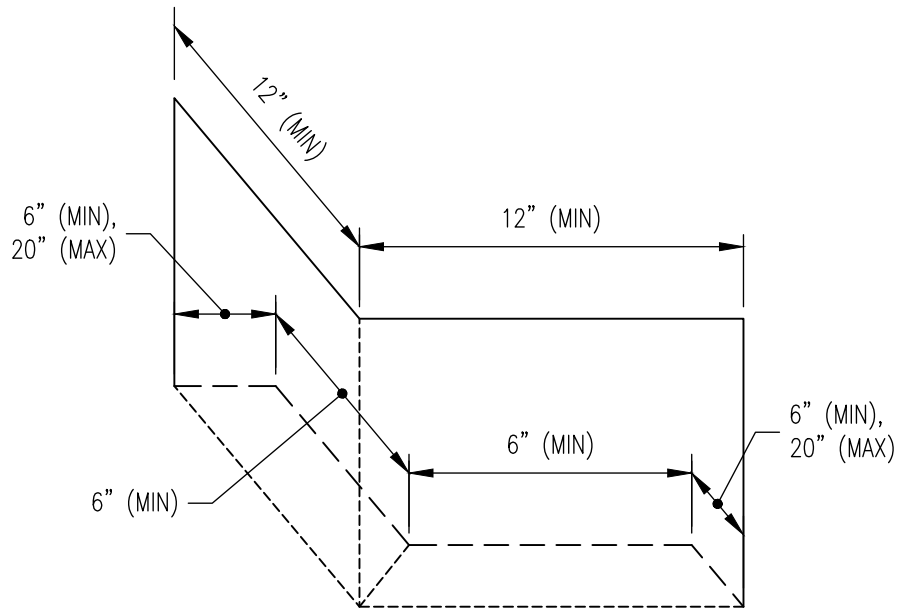

6 SOFFIT OUTSIDE CORNER
TRANSITION PANEL

NOTES:

1. ALL DIMENSIONS SHOWN ARE PANEL FACE DIMENSIONS; PANEL RETURN LEGS NOT SHOWN FOR CLARITY
2. REFER TO A-106 FOR OVERALL PANEL SIZE LIMITS
3. COMBINED PANEL FACE DIMENSIONS ALONG TRANSITIONS CANNOT EXCEED OVERALL PANEL SIZE LIMITS



LAMINATORS
Composite Panel Solutions

www.LaminatorsInc.com

800.523.2347

TRANSITION PANEL SIZE REQUIREMENTS

ADAPTACLAD RS - 30 PSF (ASD) / 50 PSF (LRFD)
TRANSITIONS & PENETRATIONS

Date:
4/8/2024

Drawn By:
JJM

Detail Set:
AC-RS

Dwg. No.:
A-203.30

Rev:
00

PANEL CLIP SHOWN ON LONG SIDE OF PANEL; PANEL CLIP NOT REQUIRED FOR THIS SECTION ON SHORT SIDE OF PANEL

2" (NOM)
SYSTEM DEPTH
(EXCLUDING SHIM)

WALL ASSEMBLY
BY OTHERS

PANEL STIFFENERS NOT SHOWN
FOR CLARITY, TYP.

FABRICATED 6mm OMEGA-LITE FR PANEL
WITH 1" RETURN LEG, TYP.

JOINT CLIP AND INSTALLATION SCREWS
(LONG SIDE OF PANEL)

BLIND RIVET AT 24" O.C. (MAX), TYP.

PANEL JOINT \varnothing

9/16" (NOM)

6mm OMEGA-LITE FR INSERT STRIP

PERIMETER EXTRUSION, TYP.

AIR AND WATER BARRIER (DRAINAGE PLANE)
ESTABLISHED BY OTHERS

OPTIONAL SHIM
ESTABLISHED BY
OTHERS

A-301

SECTION



LAMINATORS
Composite Panel Solutions

www.LaminatorsInc.com

800.523.2347

HORIZONTAL JOINT DETAIL

ADAPTACLAD RS

ARCHITECTURAL DESIGN DETAILS

Date:
4/8/2024

Drawn By:
JJM

Detail Set:
AC-RS

Dwg. No.:
A-301

Rev:
00

PANEL CLIP NOT SHOWN ON SHORT SIDE OF PANEL; PANEL CLIP REQUIRED FOR THIS SECTION ON LONG SIDE OF PANEL

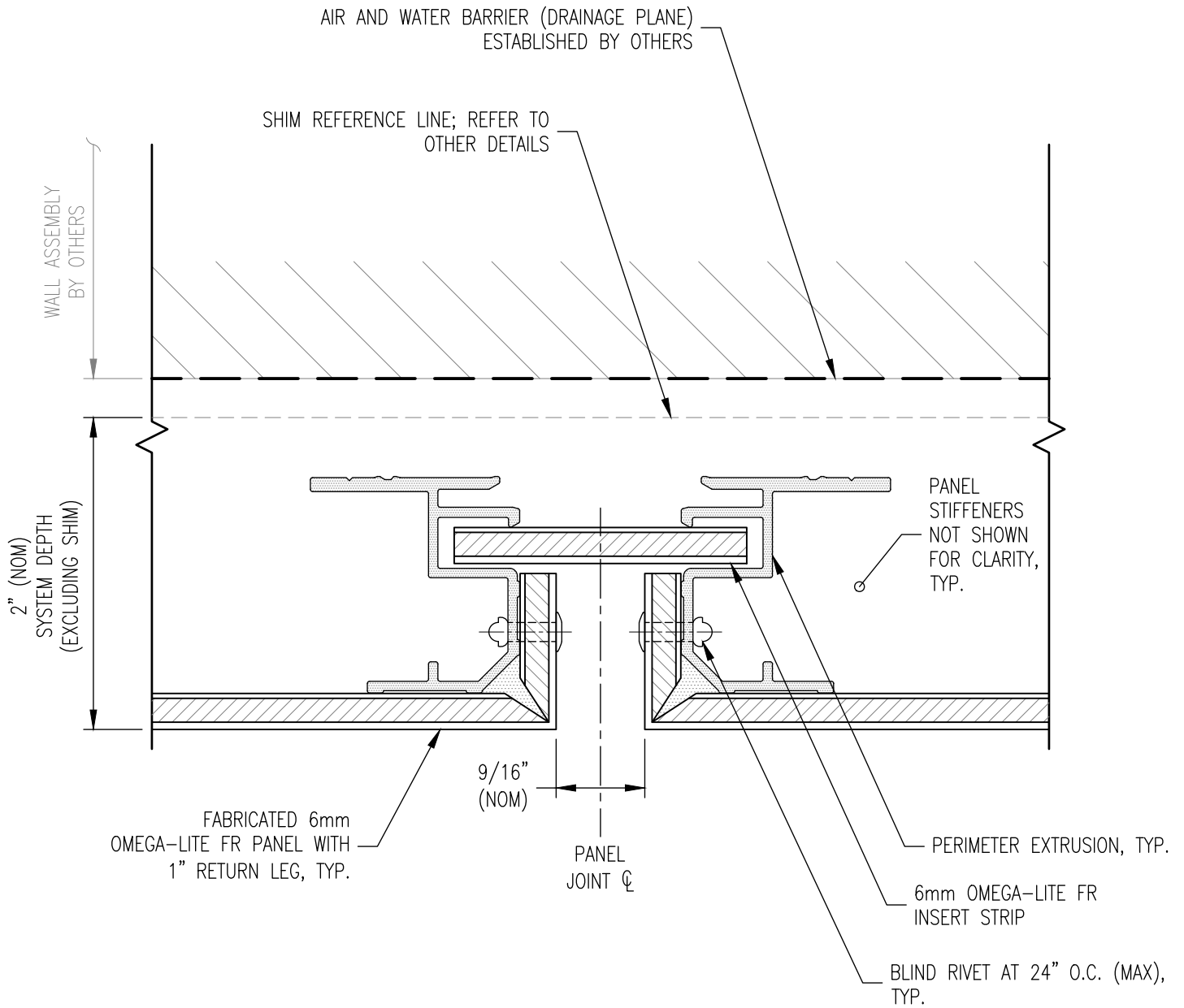

A-302 PLAN SECTION



www.LaminatorsInc.com

800.523.2347

VERTICAL JOINT DETAIL
 ADAPTACLAD RS
 ARCHITECTURAL DESIGN DETAILS

Date: 4/8/2024	Drawn By: JJM	Detail Set: AC-RS	Dwg. No.: A-302	Rev: 00
-------------------	------------------	----------------------	--------------------	------------

PANEL CLIP SHOWN ON LONG SIDE OF PANEL; PANEL CLIP NOT REQUIRED FOR THIS SECTION ON SHORT SIDE OF PANEL

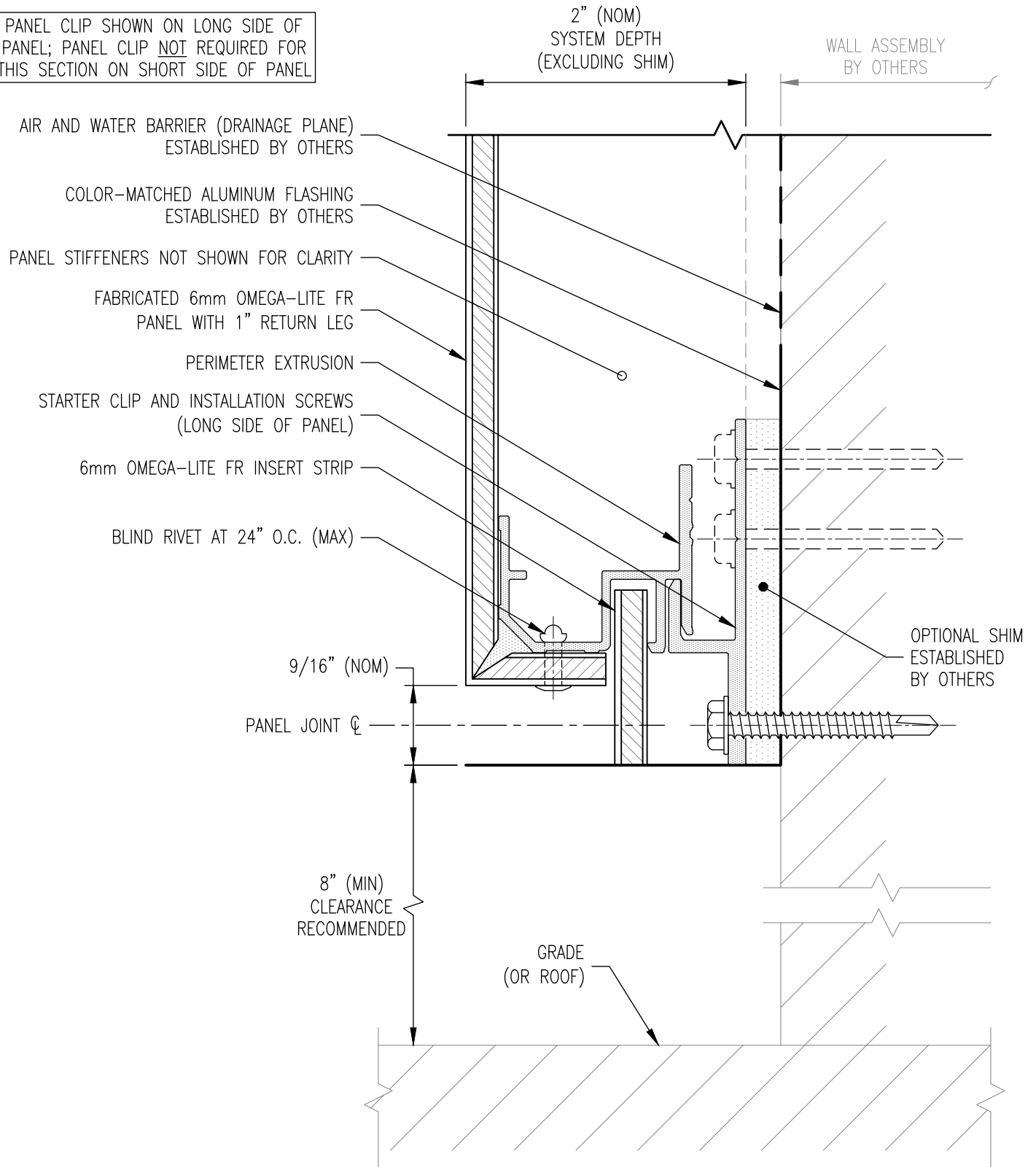

A-303 SECTION



www.LaminatorsInc.com

800.523.2347

BOTTOM HORIZONTAL EDGE DETAIL
 ADAPTACLAD RS
 ARCHITECTURAL DESIGN DETAILS

Date: 4/8/2024	Drawn By: JJM	Detail Set: AC-RS	Dwg. No.: A-303	Rev: 00
-------------------	------------------	----------------------	--------------------	------------

PANEL CLIP SHOWN ON LONG SIDE OF PANEL; PANEL CLIP NOT REQUIRED FOR THIS SECTION ON SHORT SIDE OF PANEL

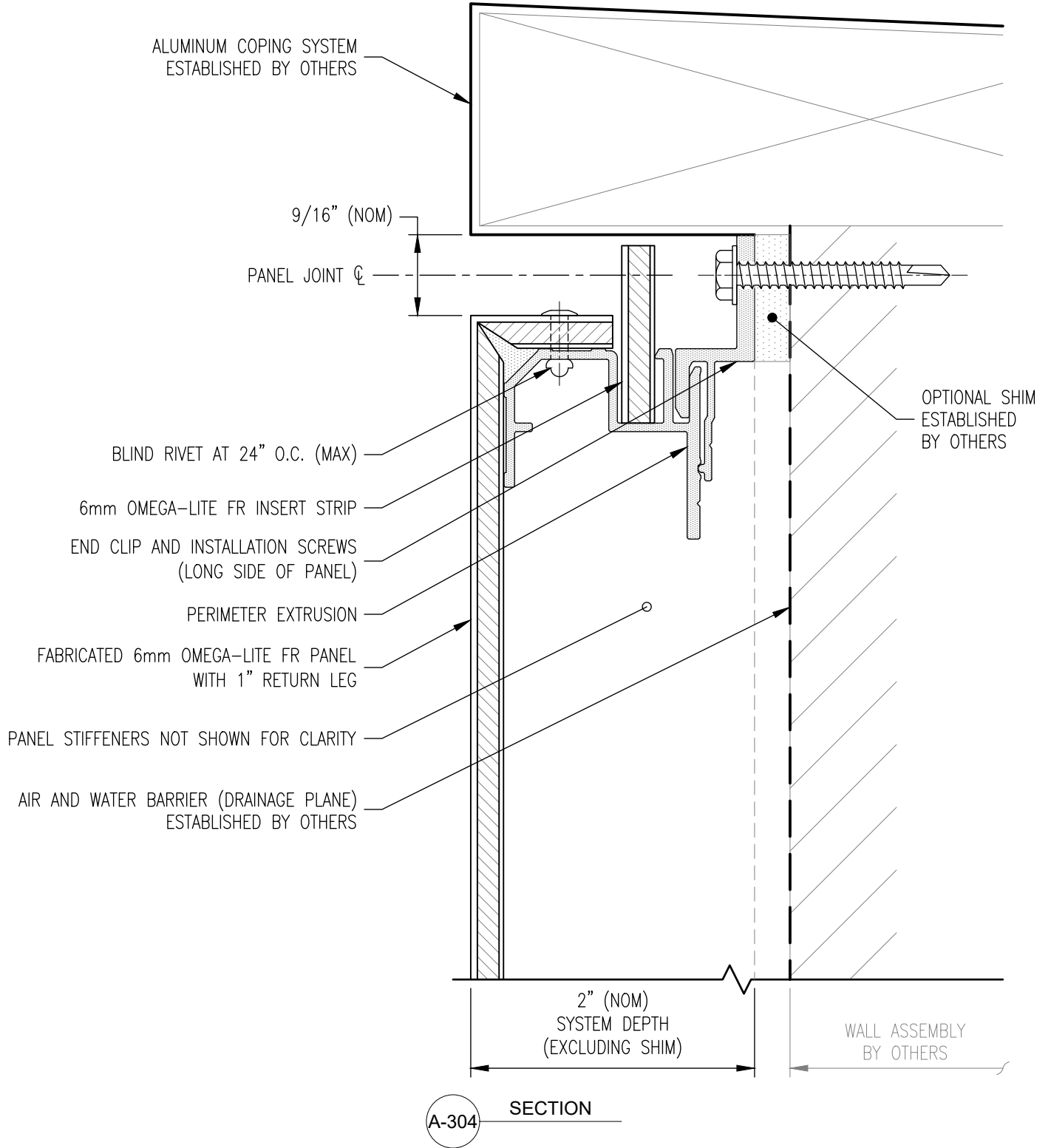

LAMINATORS
Composite Panel Solutions

www.LaminatorsInc.com

800.523.2347

TOP HORIZONTAL EDGE DETAIL

ADAPTACLAD RS

ARCHITECTURAL DESIGN DETAILS

Date:
4/8/2024

Drawn By:
JJM

Detail Set:
AC-RS

Dwg. No.:
A-304

Rev:
00

PANEL CLIP NOT SHOWN ON SHORT SIDE OF PANEL; PANEL CLIP REQUIRED FOR THIS SECTION ON LONG SIDE OF PANEL

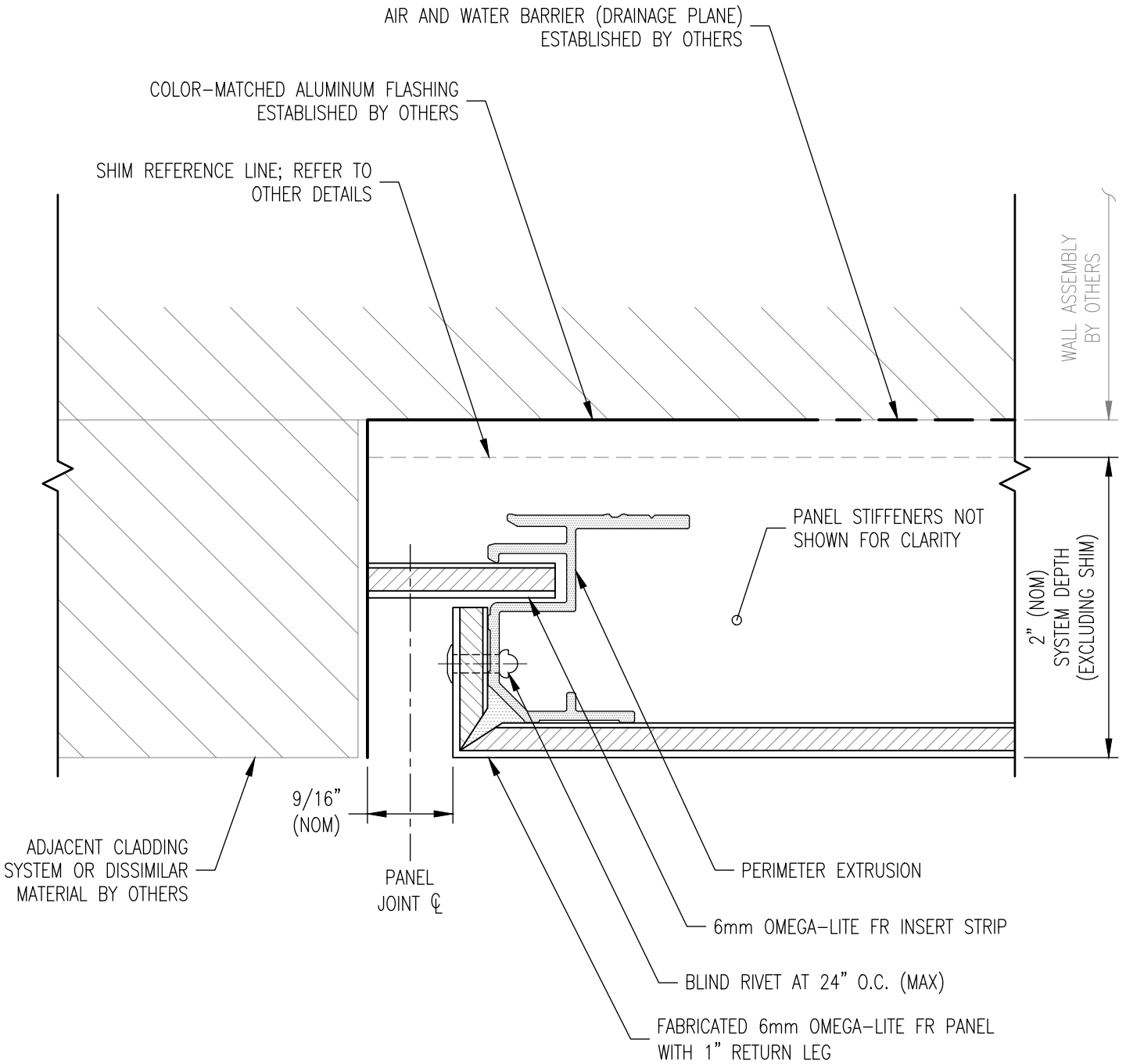

A-305 PLAN SECTION



www.LaminatorsInc.com

800.523.2347

LEFT VERTICAL EDGE DETAIL
 ADAPTACLAD RS
 ARCHITECTURAL DESIGN DETAILS

Date: 4/8/2024	Drawn By: JJM	Detail Set: AC-RS	Dwg. No.: A-305	Rev: 00
-------------------	------------------	----------------------	--------------------	------------

PANEL CLIP NOT SHOWN ON SHORT SIDE OF PANEL; PANEL CLIP REQUIRED FOR THIS SECTION ON LONG SIDE OF PANEL

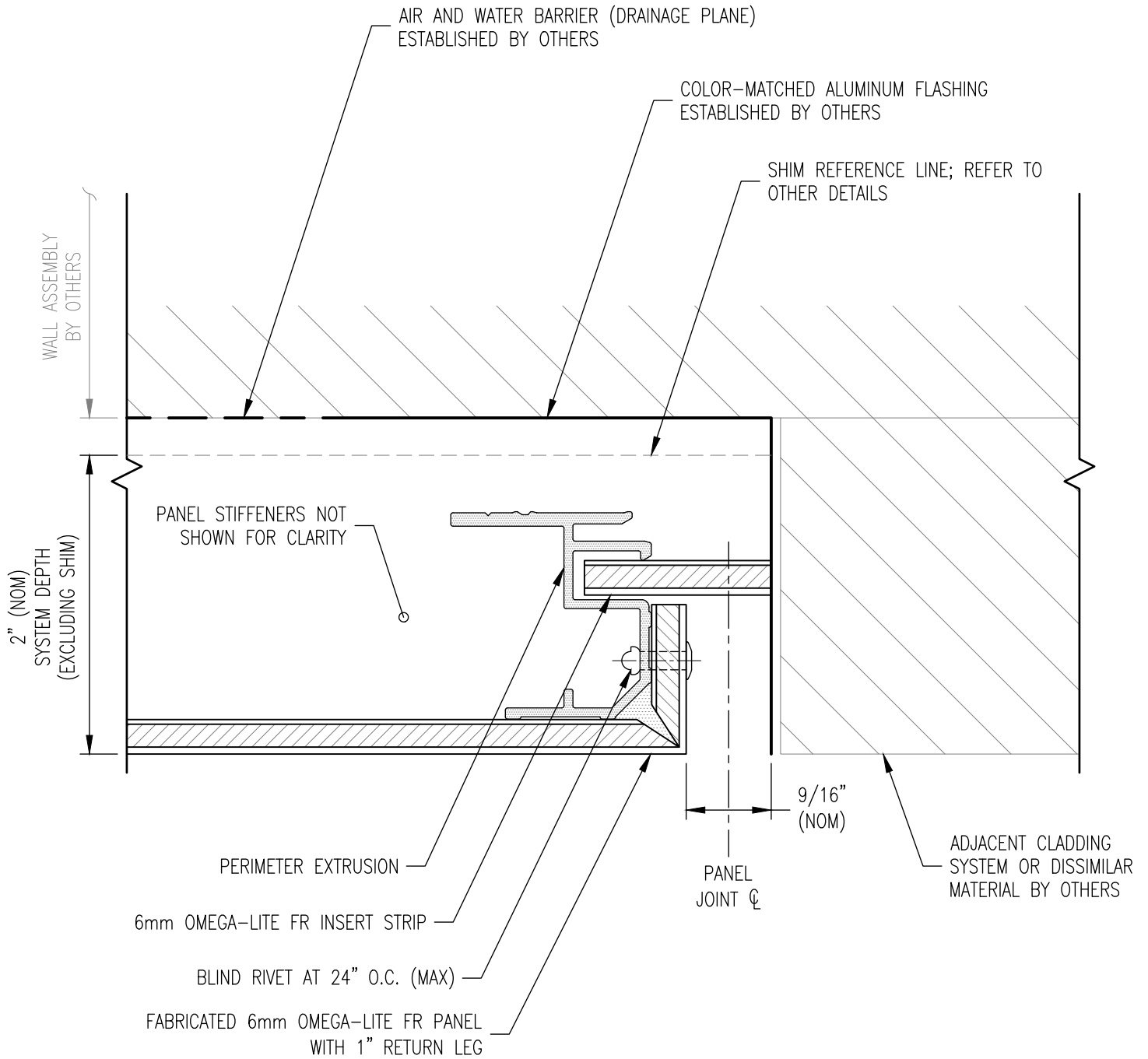

A-306 PLAN SECTION



www.LaminatorsInc.com

800.523.2347

RIGHT VERTICAL EDGE DETAIL
 ADAPTACLAD RS
 ARCHITECTURAL DESIGN DETAILS

Date: 4/8/2024	Drawn By: JJM	Detail Set: AC-RS	Dwg. No.: A-306	Rev: 00
-------------------	------------------	----------------------	--------------------	------------

PANEL CLIP SHOWN ON LONG SIDE OF PANEL; PANEL CLIP NOT REQUIRED FOR THIS SECTION ON SHORT SIDE OF PANEL

2" (NOM)
SYSTEM DEPTH
(EXCLUDING SHIM)

WALL ASSEMBLY
BY OTHERS

AIR AND WATER BARRIER (DRAINAGE PLANE)
ESTABLISHED BY OTHERS

COLOR-MATCHED ALUMINUM FLASHING
ESTABLISHED BY OTHERS

PANEL STIFFENERS NOT SHOWN FOR CLARITY

FABRICATED 6mm OMEGA-LITE FR PANEL
WITH 1" RETURN LEG

PERIMETER EXTRUSION

STARTER CLIP AND INSTALLATION SCREWS
(LONG SIDE OF PANEL)

6mm OMEGA-LITE FR INSERT STRIP

BLIND RIVET AT 24" O.C. (MAX)

9/16" (NOM)

PANEL JOINT C

OPTIONAL SHIM
ESTABLISHED
BY OTHERS

STEEL FLASHING
(22 GA. MIN)
REQUIRED FOR
NFPA 285
COMPLIANCE
ABOVE WINDOWS
ONLY (SEE NOTE)

WINDOW (OR DOOR) SYSTEM
BY OTHERS

NOTE: ADDITIONAL STEEL FLASHING AT HEAD AND JAMB CONDITIONS IS REQUIRED FOR INSTALLATIONS OVER LAMINATORS OMEGA CI PRODUCT; CONTACT LAMINATORS TECHNICAL SUPPORT FOR FURTHER INFORMATION

A-307

SECTION



LAMINATORS
Composite Panel Solutions

www.LaminatorsInc.com

800.523.2347

WINDOW (OR DOOR) HEAD DETAIL

ADAPTACLAD RS

ARCHITECTURAL DESIGN DETAILS

Date:
4/8/2024

Drawn By:
JJM

Detail Set:
AC-RS

Dwg. No.:
A-307

Rev:
00

PANEL CLIP SHOWN ON LONG SIDE OF PANEL; PANEL CLIP NOT REQUIRED FOR THIS SECTION ON SHORT SIDE OF PANEL

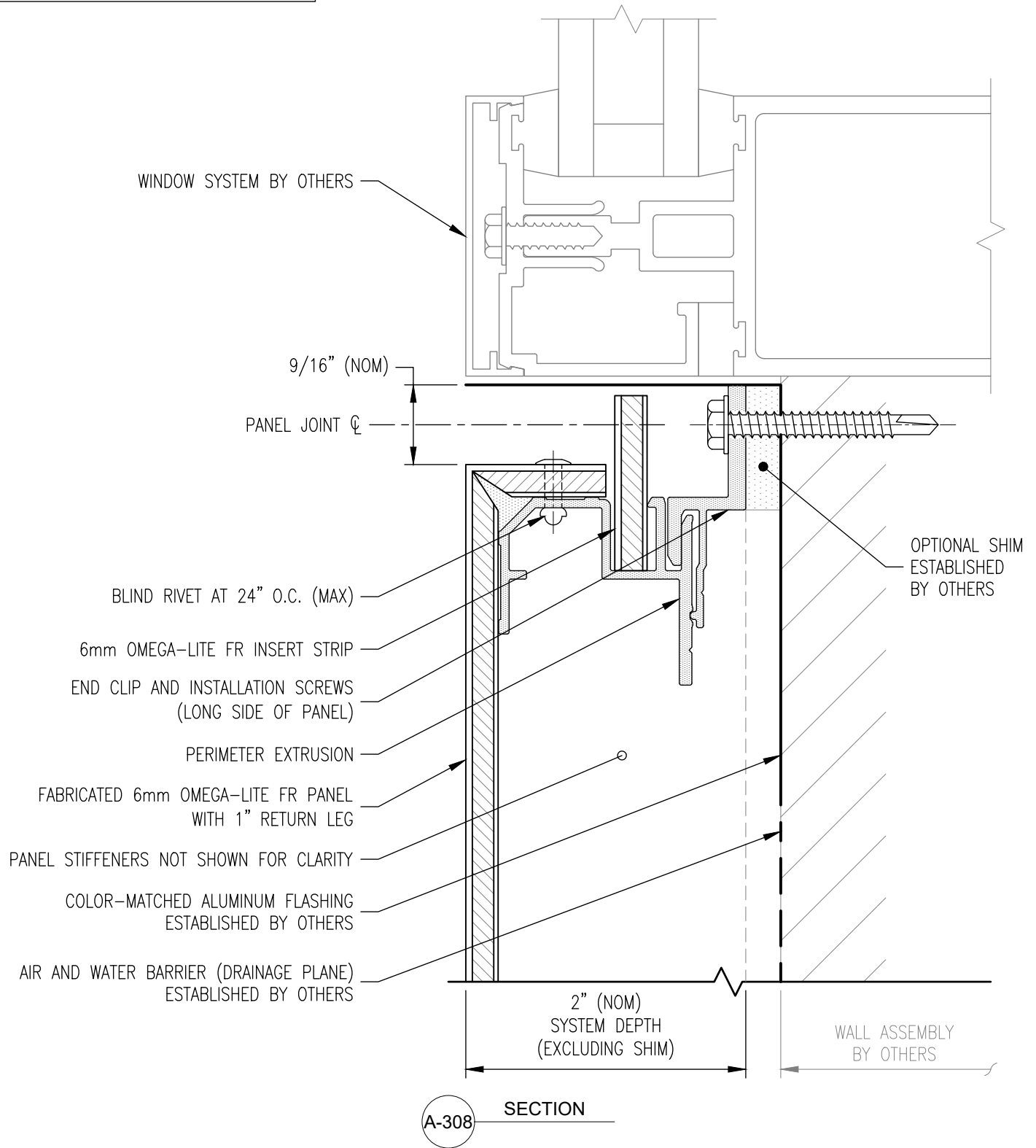

LAMINATORS
Composite Panel Solutions

www.LaminatorsInc.com

800.523.2347

WINDOW SILL DETAIL
ADAPTACLAD RS
ARCHITECTURAL DESIGN DETAILS

Date: 4/8/2024	Drawn By: JJM	Detail Set: AC-RS	Dwg. No.: A-308	Rev: 00
-------------------	------------------	----------------------	--------------------	------------

PANEL CLIP NOT SHOWN ON SHORT SIDE OF PANEL; PANEL CLIP REQUIRED FOR THIS SECTION ON LONG SIDE OF PANEL

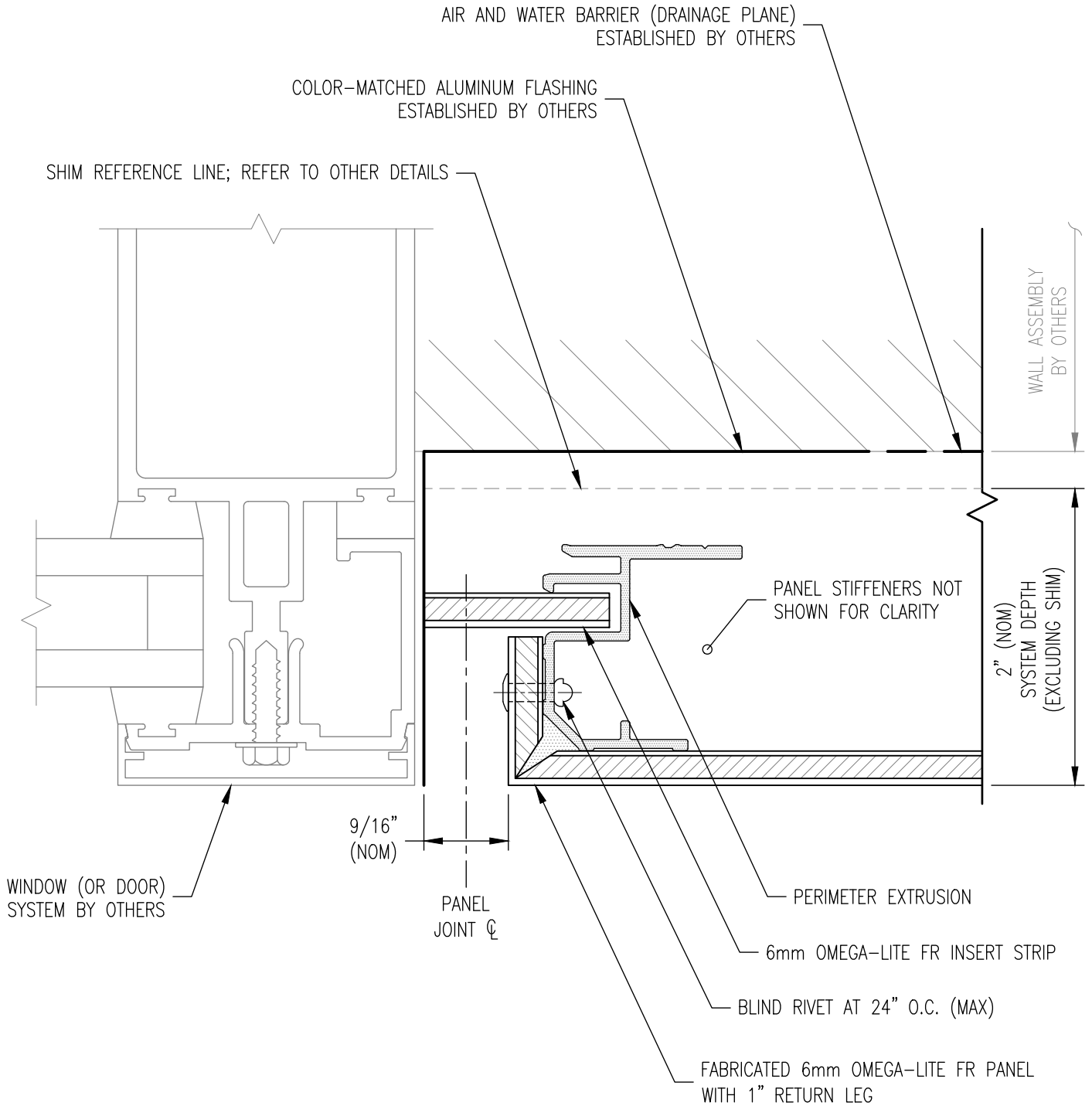

A-309 PLAN SECTION



www.LaminatorsInc.com

800.523.2347

LEFT VERTICAL EDGE DETAIL AT WINDOW (OR DOOR) JAMB
 ADAPTACLAD RS
 ARCHITECTURAL DESIGN DETAILS

Date: 4/8/2024	Drawn By: JJM	Detail Set: AC-RS	Dwg. No.: A-309	Rev: 00
-------------------	------------------	----------------------	--------------------	------------

PANEL CLIP NOT SHOWN ON SHORT SIDE OF PANEL; PANEL CLIP REQUIRED FOR THIS SECTION ON LONG SIDE OF PANEL

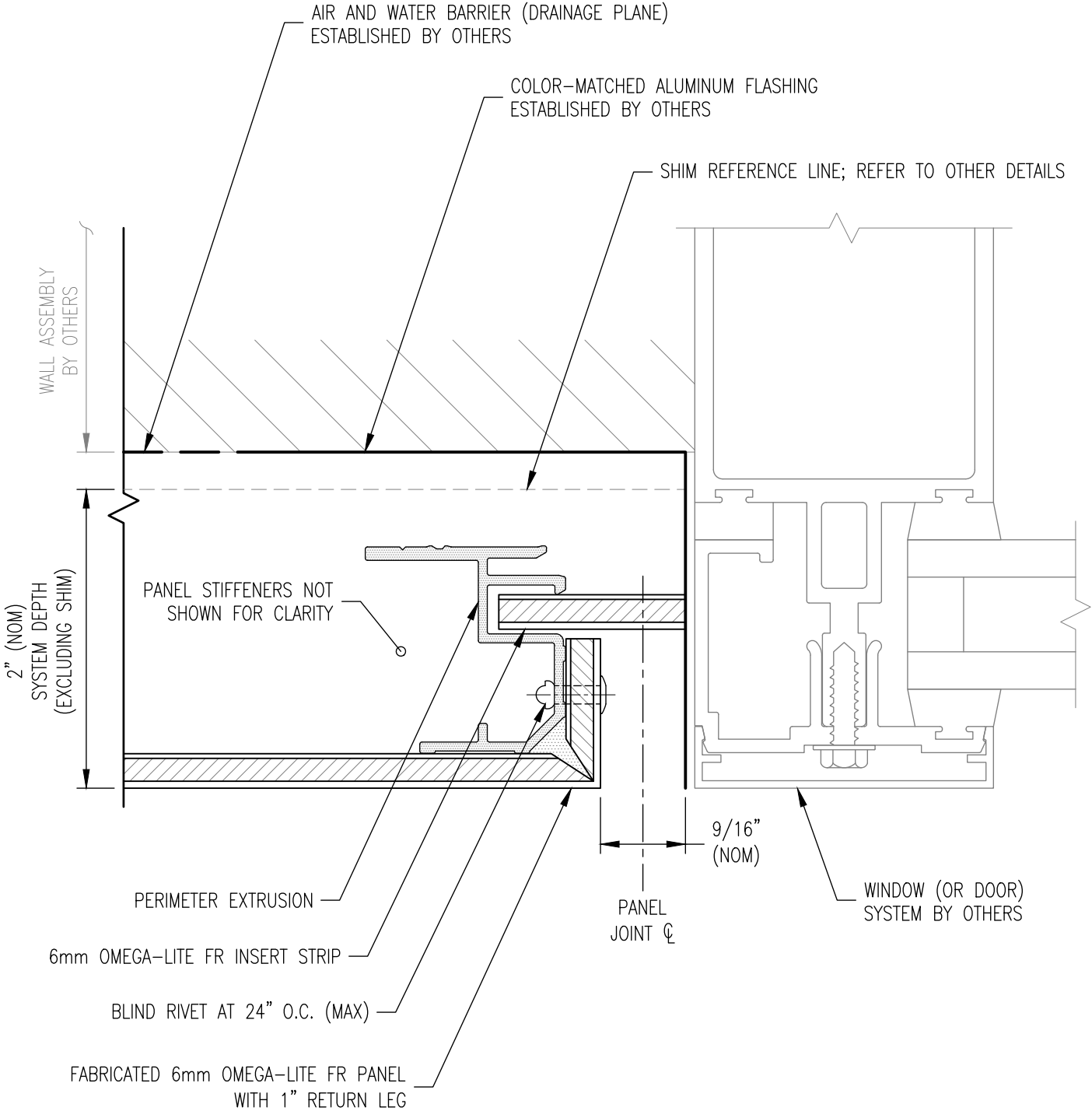

A-310 PLAN SECTION



www.LaminatorsInc.com

800.523.2347

RIGHT VERTICAL EDGE DETAIL AT WINDOW (OR DOOR) JAMB
 ADAPTACLAD RS
 ARCHITECTURAL DESIGN DETAILS

Date: 4/8/2024	Drawn By: JJM	Detail Set: AC-RS	Dwg. No.: A-310	Rev: 00
-------------------	------------------	----------------------	--------------------	------------

SHIM REFERENCE LINE; REFER TO OTHER DETAILS

WALL ASSEMBLY BY OTHERS

2" (NOM) SYSTEM DEPTH (EXCLUDING SHIM)

REINFORCING ANGLE

PANEL STIFFENERS NOT SHOWN FOR CLARITY

FABRICATED 6mm OMEGA-LITE FR PANEL

AIR AND WATER BARRIER (DRAINAGE PLANE) ESTABLISHED BY OTHERS

A-311 PLAN SECTION



LAMINATORS
Composite Panel Solutions

www.LaminatorsInc.com

800.523.2347

INSIDE CORNER DETAIL

ADAPTACLAD RS

ARCHITECTURAL DESIGN DETAILS

Date:
4/8/2024

Drawn By:
JJM

Detail Set:
AC-RS

Dwg. No.:
A-311

Rev:
00

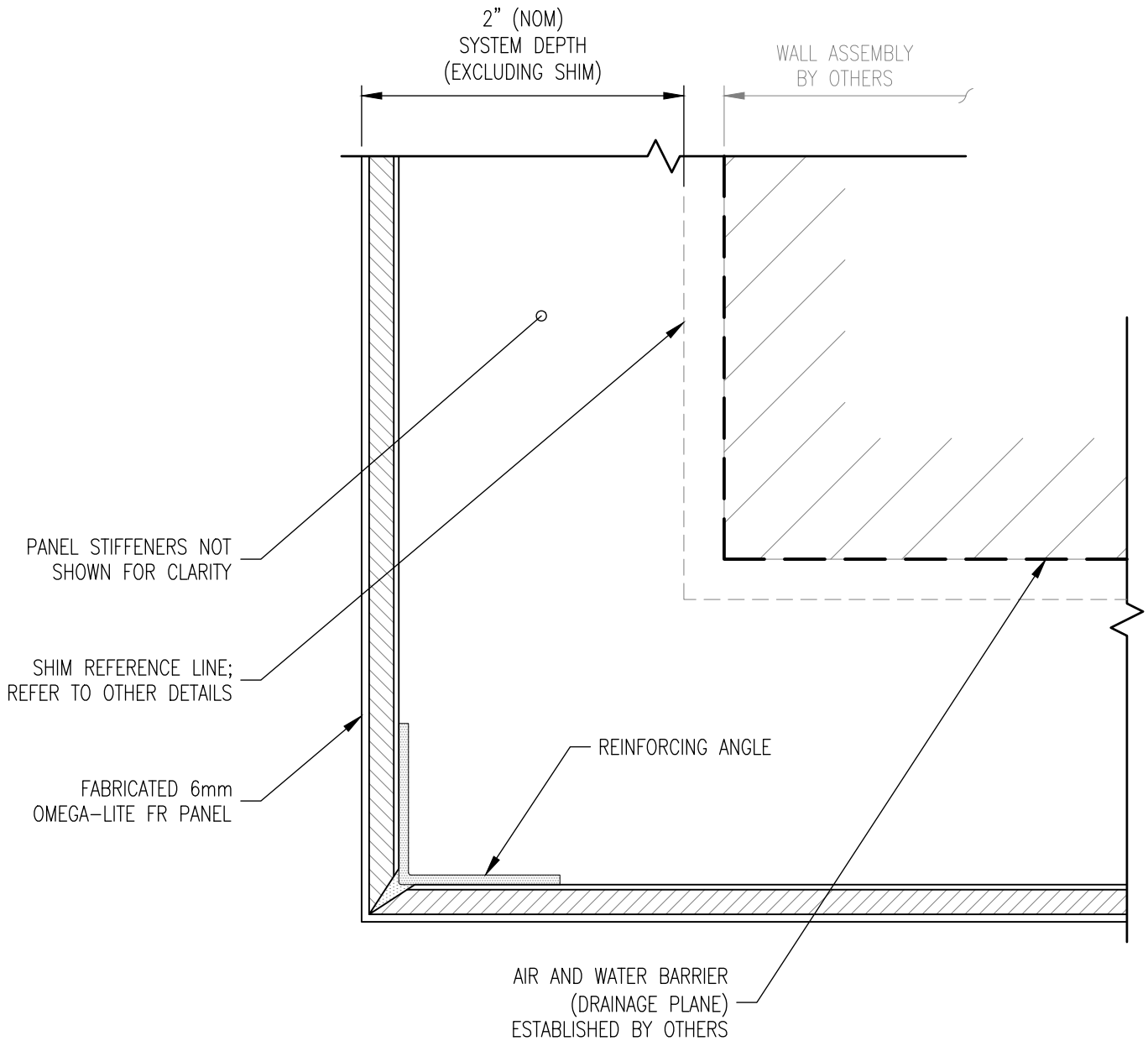

(A-312) PLAN SECTION



LAMINATORS
Composite Panel Solutions

www.LaminatorsInc.com

800.523.2347

OUTSIDE CORNER DETAIL

ADAPTACLAD RS

ARCHITECTURAL DESIGN DETAILS

Date:
4/8/2024

Drawn By:
JJM

Detail Set:
AC-RS

Dwg. No.:
A-312

Rev:
00

PANEL CLIP SHOWN ON LONG SIDE OF PANEL; PANEL CLIP NOT REQUIRED FOR THIS SECTION ON SHORT SIDE OF PANEL

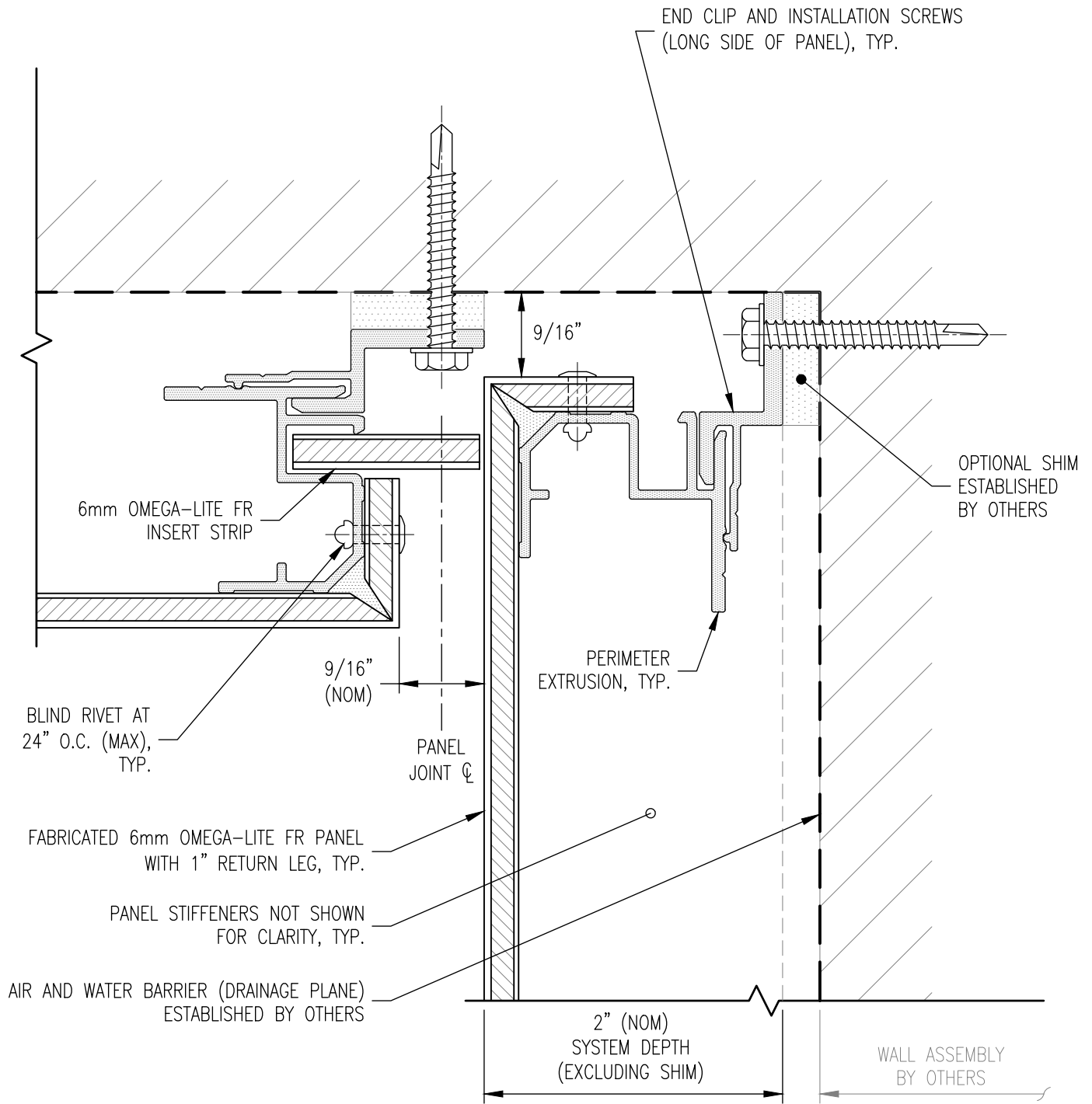

A-313 SECTION



www.LaminatorsInc.com

800.523.2347

SOFFIT-TO-WALL TRANSITION DETAIL
 ADAPTACLAD RS
 ARCHITECTURAL DESIGN DETAILS

Date: 4/8/2024	Drawn By: JJM	Detail Set: AC-RS	Dwg. No.: A-313	Rev: 00
-------------------	------------------	----------------------	--------------------	------------

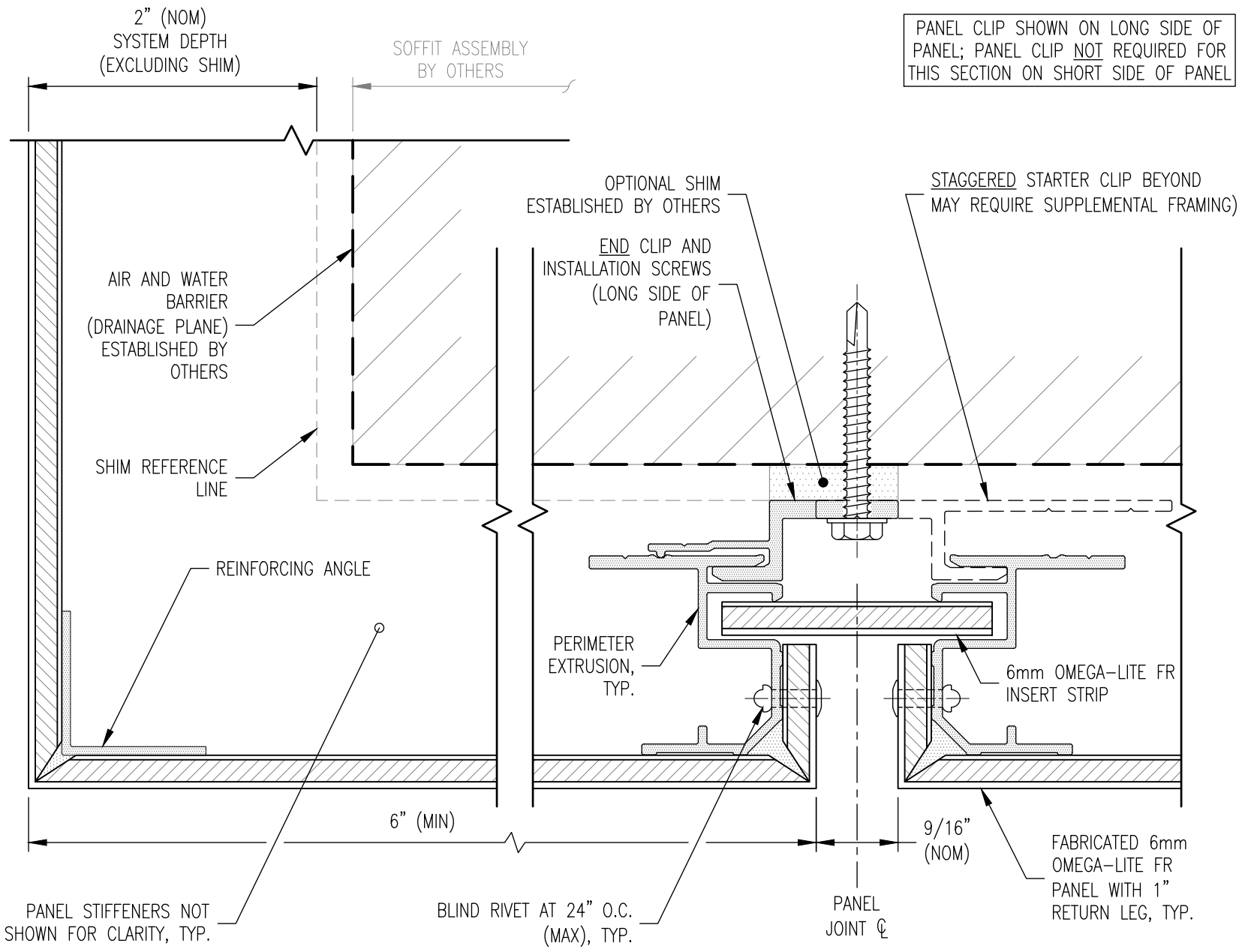

A-314 SECTION
(ORIENT DETAIL THIS DIRECTION)

FASCIA-TO-SOFFIT TRANSITION DETAIL
ADAPTA CLAD RS
ARCHITECTURAL DESIGN DETAILS

Date:	4/8/2024
Drawn By:	JJM
Detail Set:	AC-RS
Dwg. No.:	A-314
Rev.:	00

LAMINATORS
Composite Panel Solutions

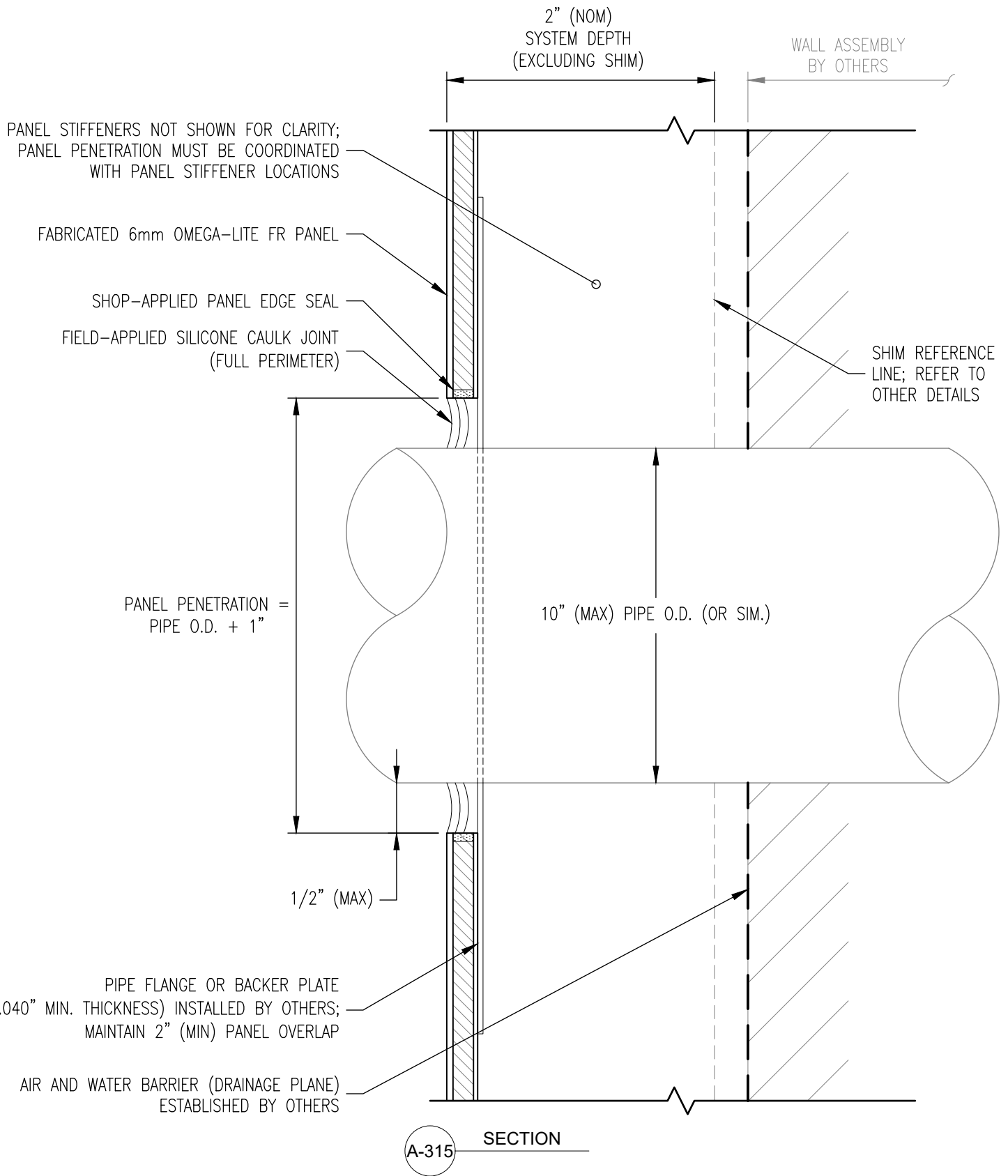

LAMINATORS
Composite Panel Solutions

www.LaminatorsInc.com

800.523.2347

PANEL PENETRATION DETAIL

ADAPTACLAD RS

ARCHITECTURAL DESIGN DETAILS

Date:
4/8/2024

Drawn By:
JJM

Detail Set:
AC-RS

Dwg. No.:
A-315

Rev:
00

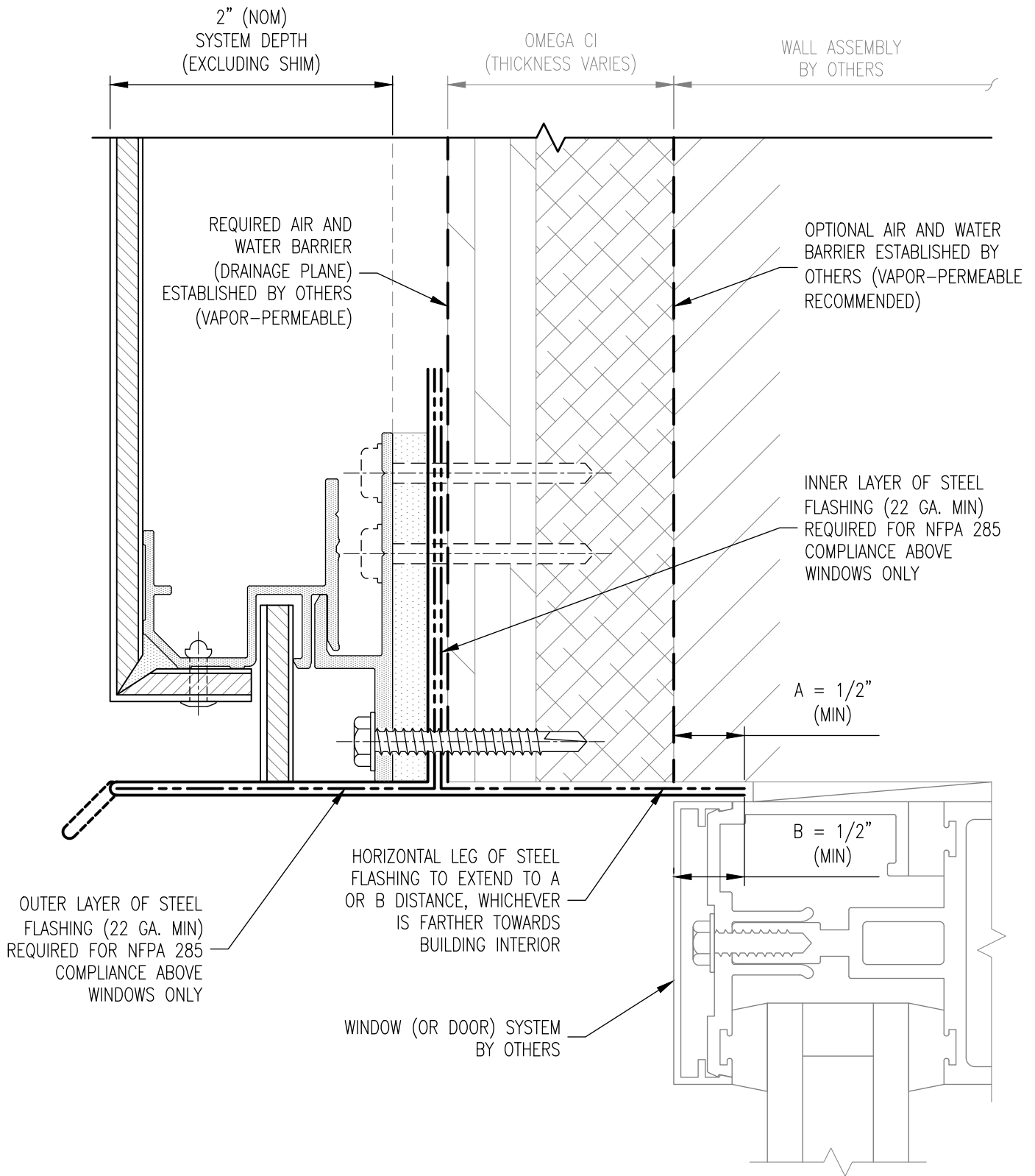

NOTE: REFER TO ADAPTA CLAD RS ARCHITECTURAL DESIGN DETAIL A-307 FOR TYPICAL COMPONENTS NOT ANNOTATED

A-351 SECTION



www.LaminatorsInc.com

800.523.2347

WINDOW HEAD (OR DOOR) DETAIL OVER OMEGA CI

ADAPTA CLAD RS
ARCHITECTURAL DESIGN DETAILS

Date:
5/7/2024

Drawn By:
JJM

Detail Set:
AC-RS

Dwg. No.:
A-351

Rev:
00

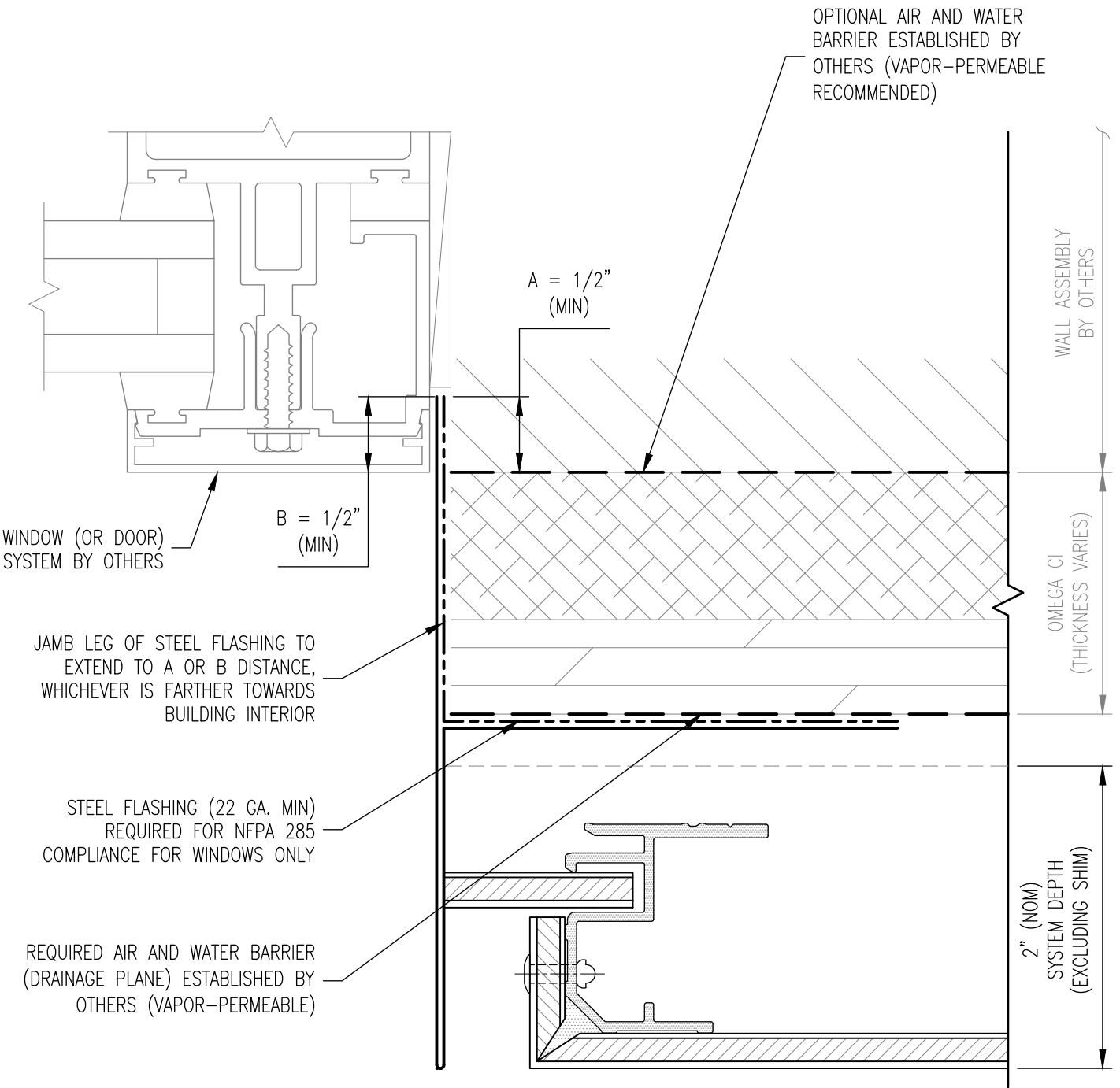

NOTE: REFER TO ADAPTA CLAD RS ARCHITECTURAL DESIGN DETAIL A-309 FOR TYPICAL COMPONENTS NOT ANNOTATED

A-352 PLAN SECTION



www.LaminatorsInc.com

800.523.2347

VERTICAL EDGE DETAIL AT WINDOW (OR DOOR) JAMB OVER OMEGA CI
 ADAPTA CLAD RS
 ARCHITECTURAL DESIGN DETAILS

Date: 5/7/2024	Drawn By: JJM	Detail Set: AC-RS	Dwg. No.: A-352	Rev: 00
-------------------	------------------	----------------------	--------------------	------------

PANEL CLIP SHOWN ON LONG SIDE OF PANEL; PANEL CLIP NOT REQUIRED FOR THIS SECTION ON SHORT SIDE OF PANEL

2" (NOM)
SYSTEM DEPTH
(EXCLUDING SHIM)

WALL ASSEMBLY
BY OTHERS

PANEL STIFFENERS NOT SHOWN
FOR CLARITY, TYP.

FABRICATED 6mm OMEGA-LITE FR PANEL
WITH 1" RETURN LEG, TYP.

STARTER CLIP AND INSTALLATION SCREWS
(LONG SIDE OF PANEL)

BLIND RIVET AT 24" O.C. (MAX), TYP.

OPTIONAL SHIM
ESTABLISHED
BY OTHERS

1-1/8" (MIN) TO 4" (MAX)

PANEL
JOINT ϕ

0" TO 2-7/8" (MAX)

6mm OMEGA-LITE FR INSERT STRIP

END CLIP AND INSTALLATION SCREWS
(LONG SIDE OF PANEL)

PERIMETER EXTRUSION, TYP.

AIR AND WATER BARRIER (DRAINAGE PLANE)
ESTABLISHED BY OTHERS

A-401

SECTION



LAMINATORS
Composite Panel Solutions

www.LaminatorsInc.com

800.523.2347

HORIZONTAL JOINT DETAIL - CUSTOM WIDTH

ADAPTACLAD RS

ARCHITECTURAL DESIGN DETAILS

Date:
4/8/2024

Drawn By:
JJM

Detail Set:
AC-RS

Dwg. No.:
A-401

Rev:
00

PANEL CLIP NOT SHOWN ON SHORT SIDE OF PANEL; PANEL CLIP REQUIRED FOR THIS SECTION ON LONG SIDE OF PANEL

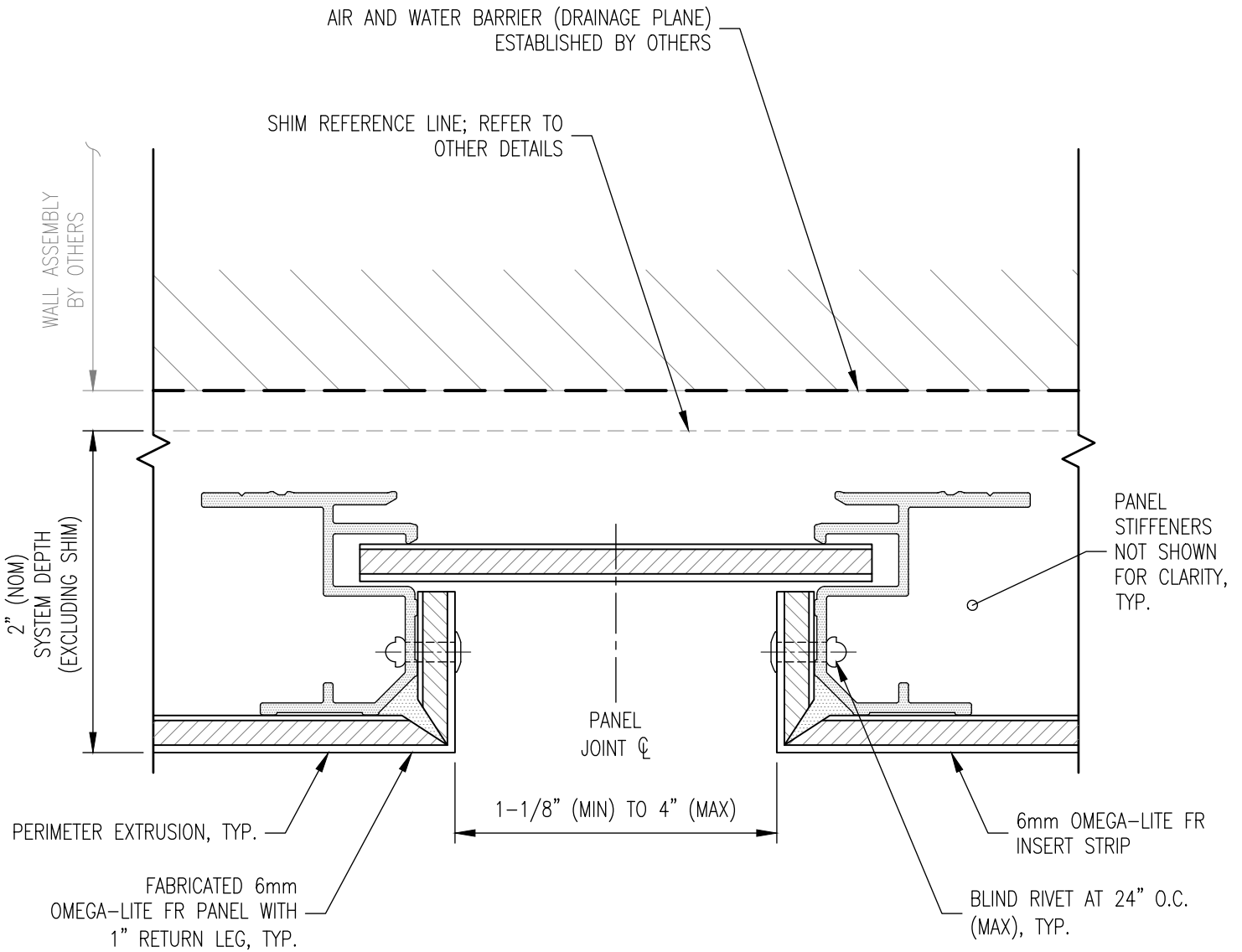

A-402 PLAN SECTION



www.LaminatorsInc.com

800.523.2347

VERTICAL JOINT DETAIL - CUSTOM WIDTH
 ADAPTACLAD RS
 ARCHITECTURAL DESIGN DETAILS

Date: 4/8/2024	Drawn By: JJM	Detail Set: AC-RS	Dwg. No.: A-402	Rev: 00
-------------------	------------------	----------------------	--------------------	------------

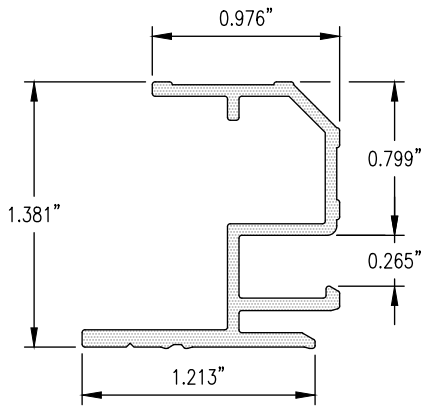

PERIMETER EXTRUSION

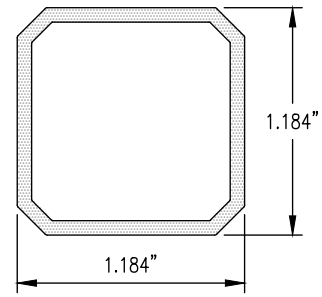

PANEL STIFFENER

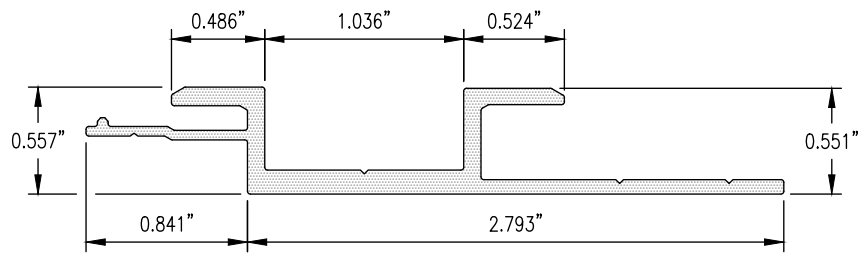

JOINT CLIP

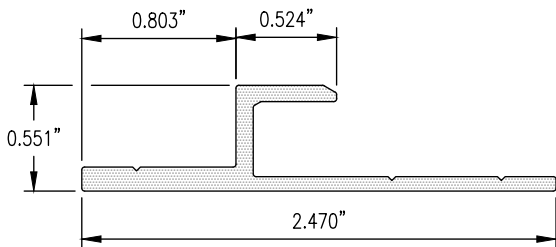

STARTER CLIP

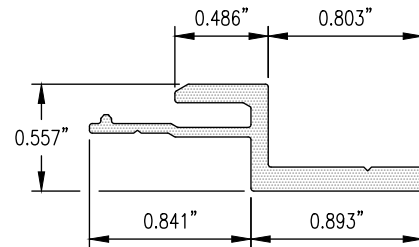

END CLIP



LAMINATORS
Composite Panel Solutions

www.LaminatorsInc.com

800.523.2347

SHAPE PROFILES

ADAPTACLAD RS

MISCELLANEOUS DETAILS

Date:
4/8/2024

Drawn By:
JJM

Detail Set:
AC-RS

Dwg. No.:
M-101

Rev:
00

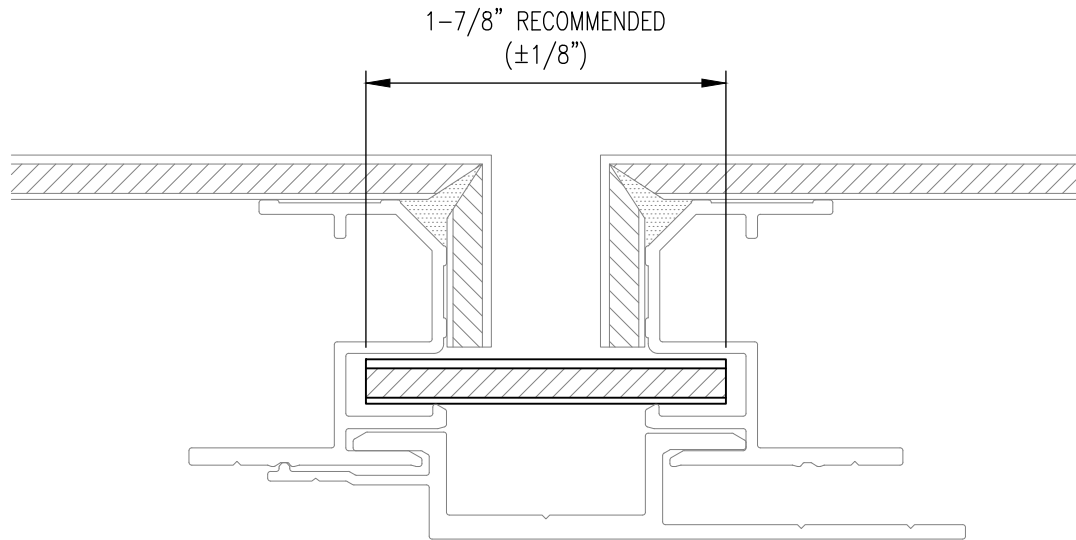

VERTICAL AND HORIZONTAL JOINTS

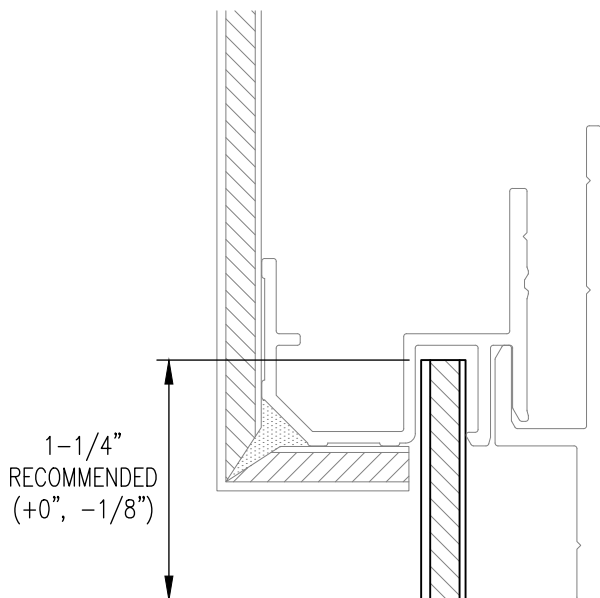

BOTTOM HORIZONTAL, LEFT VERTICAL,
AND RIGHT VERTICAL EDGES

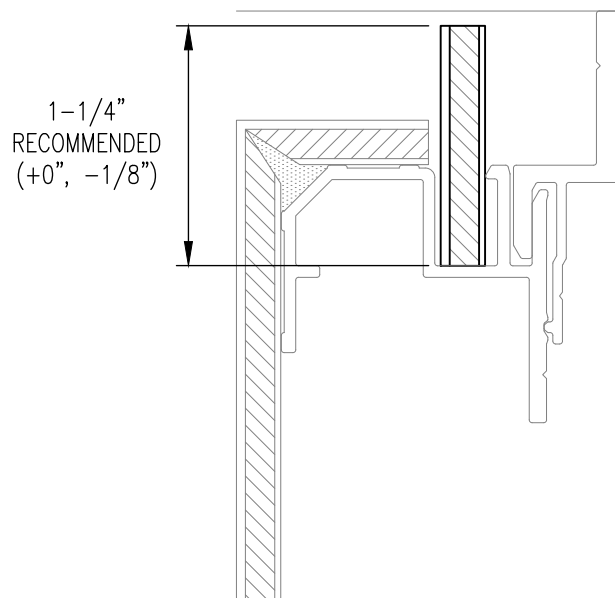

TOP HORIZONTAL EDGE



LAMINATORS
Composite Panel Solutions

www.LaminatorsInc.com

800.523.2347

INSERT STRIP SIZES

ADAPTACLAD RS

MISCELLANEOUS DETAILS

Date:
4/8/2024

Drawn By:
JJM

Detail Set:
AC-RS

Dwg. No.:
M-102

Rev:
00